

Nyon

Online Version (BUI350)



en Original operating instructions

Table of Contents

Introduction	6
About Warnings	6
General Warnings.....	6
Using your Manual	7
Graphics	7
Safety instructions	8
Safety Instructions in Conjunction with the Navigation System.....	9
Safety Instructions for Charging the On-Board Computer Battery .	10
Privacy notice.....	13
Congratulations	13
Product Description and Specifications	14
Product Features	15
Intended Use	17
Technical Data.....	17
Assembly	19
Inserting and removing the on-board computer	20
Operation	22
Setting up the eBike system.....	22
Requirements	22
Switching the eBike system on/off	22
Standby mode	23
Energy supply of the on-board computer	23
Battery Charge Indicator	24
Starting operation of the on-board computer.....	25
Creating a user ID	25
Connecting the on-board computer to the portal.....	26
Connecting the On-Board Computer with the Bosch eBike Connect App.....	26
Setting the assistance level.....	26
Switching the push assistance on/off	27
Switching bicycle lights on/off.....	28

Lock (premium function)	28
Compatibility	29
Setting up the Lock function	29
How it works	29
Replacing eBike components and the Lock function	30
Activity tracking	31
eShift (optional)	31
Software Updates	31
Notes on cycling with the eBike system	32
Taking care of your eBike	32
The Nyon operating system	32
Premium functions	33
User management	34
Displays and settings of the on-board computer	35
<Status Screen>	36
<Settings>	37
<Ride Screen>	39
<Trip Data Screen>	41
<Map Screen>	42
Active Navigation	45
Range display	46
<Analysis Screen>	47
Creating custom screens	48
<Fitness Screen> (predefined screen)	49
<eMTB Screen> (predefined screen)	50
<Basic Screen> (predefined screen)	51
<Quick Menu>	51
Displays and settings of the Bosch eBike Connect smartphone app	53
Activation of the Bosch eBike Connect Application	53
Registration via Smartphone	53
Main Menu of Bosch eBike Connect	55
<Activities> menu item	56

<Map> menu item.....	56
<My eBike> menu item	57
<Shop> menu item.....	57
Displays and Settings of the Online Portal	59
Online Registration.....	59
Online Portal Main Menu	60
<Route Planning> menu item.....	60
<Activities> menu item	63
<My eBike> menu item	63
<Help> menu item	63
Profile menu item 	63
Troubleshooting.....	66
Maintenance and cleaning	70
Battery Recycling Program.....	70

Introduction

About Warnings

This manual contains many **DANGER**, **WARNING**, and **CAUTION** indicators concerning the consequences of failure to use, assemble, maintain, store, inspect and dispose of a Bosch-equipped eBike in a safe manner.

- The combination of the safety alert symbol and the word **DANGER** indicates a hazardous situation that, if not avoided, will result in death or serious injury.
- The combination of the safety alert symbol and the word **WARNING** indicates a hazardous situation that, if not avoided, could result in death or serious injury.
- The combination of the safety alert symbol and the word **CAUTION** indicates a hazardous situation that, if not avoided, could result in minor or moderate injury.

General Warnings



Read all safety warnings and all instructions. Failure to follow the warnings and instructions may result in death or serious injury.

Save all safety warnings and instructions for future reference.

The term **battery pack** used in these operating instructions refers to all original Bosch eBike battery packs.

This manual contains important safety, performance and service information. Read it before you take the first ride on your new bicycle, and keep it for reference. The manual can also be found online at www.bosch-ebike.com.

- ▶ **This manual is intended to be read together with the separate user manual provided with your bicycle.** Be sure to read all provided documents including labels on the product before your first ride.
- ▶ **Read ALL accompanying manuals before riding the bike for the first time.** Your Bosch Drive System comes with additional manuals and documents provided by the manufacturer of the bicycle and other components. Failure to read and understand safety information can result in death or serious injury.

- ▶ **Take responsibility for your own SAFETY.** If you have any questions or do not understand something, consult with your dealer or the bicycle or component manufacturer.
- ▶ **Some eBike accessories may present a choking hazard to small children.** Keep these accessories away from children.

The Bosch Drive System adds weight to your bicycle which you may not be used to lift. Avoid injury, use proper lifting techniques.

Using your Manual

In addition to the functions outlined here, changes to software relating to troubleshooting and functional modifications may be introduced at any time.

Graphics

The bicycle shown in this manual may differ slightly from your bicycle, but will be similar enough to help you understand our instructions.

RIGHT-HAND and LEFT-HAND sides are determined by facing in the direction the bicycle will travel when going forward. When you see a broken line (-----), the item referred to is hidden from view.

Safety instructions



Read all the safety information and instructions. Failure to observe the safety information and follow instructions may result in electric shock, fire and/or serious injury.

Save all safety warnings and instructions for future reference.

The term **battery pack** used in these operating instructions refers to all original Bosch eBike battery packs.

- ▶ **Do not allow yourself to be distracted by the display of the on-board computer.** If you do not concentrate exclusively on the traffic around you, you risk being involved in an accident. If you want to change any settings on the on-board computer other than the assistance level, always stop before entering the relevant data.
- ▶ **Set the display brightness such that you can adequately see important information like speed or warning symbols.** An incorrectly set display brightness can result in dangerous situations.
- ▶ **Before commencing a training program, please consult a doctor to confirm that you are able to cope with any stresses that the program may place on you.** Only this way can you ensure that you will not be subject to any potential overexertion.
- ▶ **When using a heart rate monitor, the heart frequency that is shown may be distorted as a result of electromagnetic interference.** The heart frequency shown only serves as a reference. No liability can be assumed for any consequences incurred as a result of an incorrectly indicated heart frequency.
- ▶ **Nyon is not a medical product.** The values shown on the fitness screen may differ from the actual values.
- ▶ **Do not open the on-board computer.** Opening the on-board computer can result in irreparable damage and void your warranty.
- ▶ **Do not use the on-board computer as a handle.** Lifting the eBike up by the on-board computer can cause irreparable damage to the on-board computer.
- ▶ **Caution!** Using the on-board computer with *Bluetooth*® and/or WiFi can interfere with the operation of other devices and systems, including airplanes and medical devices (e.g. pacemakers, hearing aids). Similarly,

the possibility that this may cause damage to humans and animals in the immediate vicinity cannot be completely excluded. Do not use the on-board computer with *Bluetooth*[®] in the vicinity of medical devices, service stations, chemical plants, blasting areas or other areas where there is a risk of explosion. Do not use the on-board computer with *Bluetooth*[®] in airplanes. Avoid using the device in close proximity to your body over an extended period of time.

- ▶ The *Bluetooth*[®] word mark and logos are registered trademarks owned by Bluetooth SIG, Inc. and any use of such marks by Bosch eBike Systems is under licence.
- ▶ **Do not enter information or make selections while riding.** Interacting with the display unit while riding can lead to accidents causing serious injury or death. You must observe road and traffic conditions, and comply with traffic laws at all times.
- ▶ **Using your mobile device while operating an eBike may be distracting. Distracted driving is a serious safety concern and can lead to accidents causing serious injury or death. In order to prevent distracted driving, most devices come equipped with a “Do Not Disturb” mode. The “Do Not Disturb” mode should be used while operating an eBike.** Please consult your device-specific instructions for more information. You, as the eBike operator, are fully responsible for ensuring that you pay attention to road conditions and comply with traffic laws at all times.
- ▶ **Do not activate push assistance function while riding on the bike.** Only use push assistance function when pushing the eBike.

Safety Instructions in Conjunction with the Navigation System

- ▶ **Do not plan any routes while riding. Make sure that you come to a complete stop and only input a new destination while at a standstill.** If you do not concentrate exclusively on the traffic around you, you risk being involved in an accident.
- ▶ **Discontinue following your route if the navigation system suggests a path for you to take that may be risky or dangerous for you according to your capabilities as a rider.** Allow the navigation system to select an alternative route for you instead.

- ▶ **Make sure to observe all traffic signs regardless of the route proposed by the navigation system.** The navigation system is unable to take roadworks or temporary diversions into account.
- ▶ **Do not use the navigation system in circumstances where special attention must be given to safety, or if it is unclear how to proceed (road closures, diversions, etc.).** Always carry additional map sources and means of communication.
- ▶ **The navigation system instructs you to perform an unsafe or illegal maneuver.** Cancel the navigation system and choose an alternative route.
- ▶ **The navigation system directs you into an unsafe area.** Cancel the navigation system and choose an alternative route.
- ▶ **The navigation system does not direct you to the nearest emergency facility when needed.** Make an emergency call and inquire as to the quickest available route.
- ▶ **The location of the bicycle is indicated incorrectly by the navigation system.** Use a secondary source of information to determine where you are located currently.
- ▶ **The volume of the navigation system prevents you from hearing surrounding traffic while riding.** Ensure that you are able to perceive sounds from traffic in the vicinity at all times, so that you can react to potential dangers appropriately.

Safety Instructions for Charging the On-Board Computer Battery

- ▶ **Only charge the on-board computer with USB power source (5 V, 1500 mA max) and USB cable rated at least 1500 mA.** Using USB power source or USB cable not appropriately rated for the application may result in fire, explosion or personal injury.
- ▶ **Charge the on-board computer in temperatures above +32 degrees F (0 degrees C) and below +104 degrees F (40 degrees C). Store on-board computer in locations where temperatures will not exceed 104 degrees F (40 degrees C).** This is important to prevent serious damage to the battery in the on-board computer.

- ▶ **Do not expose on-board computer to fire or excessive temperature.** Exposure to fire or temperature above 212 °F (100 °C) may cause explosion.
- ▶ **Do not recharge the on-board computer (via USB port) in damp or wet environment.** Water entering on-board computer may result in electric shock or fire.
- ▶ **Never submerge on-board computer in fluid of any kind or allow fluid to enter them.** Corrosive or conductive fluid (such as seawater or industrial chemical or bleach containing products, etc.) can cause short circuit which may result in fire, personal injury and property damage.
- ▶ **Battery leakage may occur under extreme usage or temperature conditions. Avoid contact with skin and eyes.** The battery liquid is caustic and could cause chemical burns to tissues. If liquid comes in contact with skin, wash quickly with soap and water. If the liquid contacts your eyes, immediately flush eyes with water for a minimum of 15 minutes and seek medical attention.
- ▶ **Place on-board computer on flat nonflammable surfaces and away from flammable materials when recharging on-board computer using external USB power source.** Carpeting and other heat insulating surfaces block proper air circulation which may cause overheating of the on-board computer. If smoke or melting of the on-board computer is observed, unplug the external USB power source immediately and do not use the on-board computer. Contact customer service immediately.
- ▶ **Before each use, check the on-board computer, cable and plug.** If damage is detected, do not use the on-board computer. Damaged on-board computer, charging cables and plugs increase the risk of a fire, explosion and personal injury.
- ▶ **Do not disassemble on-board computer.** No user serviceable part inside. Incorrect reassembly or damage may result in fire or explosion.
- ▶ **Read and observe the safety warnings and instructions in all operating instructions of the eBike system and your eBike.**

NOTICE: This equipment complies with FCC radiation exposure limits set forth for an uncontrolled environment. This equipment should be installed and operated with minimum distance of 20 cm between the radiator and your body. This transmitter must not be co-located or operating in conjunction with any other antenna or transmitter:

1. This device must not cause harmful interference, and

2. this device must accept any interference that is received, including interference that may cause undesired operation.

NOTICE: Changes or modifications made to this equipment not expressly approved by the Robert Bosch GmbH may void the FCC authorization to operate this equipment.

NOTE: This equipment has been tested and found to comply with the limits for a Class B digital device, pursuant to Part 15 of the FCC Rules. These limits are designed to provide reasonable protection against harmful interference in a residential installation. This equipment generates, uses and can radiate radio frequency energy and, if not installed and used in accordance with the instructions, may cause harmful interference to radio communications. However, there is no guarantee that interference will not occur in a particular installation. If this equipment does cause harmful interference to radio or television reception, which can be determined by turning the equipment off and on, the user is encouraged to try to correct the interference by one or more of the following measures:

- Reorient or relocate the receiving antenna.
- Increase the separation between the equipment and receiver.
- Connect the equipment into an outlet on a circuit different from that to which the receiver is connected.
- Consult the dealer or an experienced radio/TV technician for help.

Radiofrequency radiation exposure Information: The radiated output power of the device is far below the FCC radio frequency exposure limits. Nevertheless, the device shall be used in such a manner that the potential for human contact during normal operation is minimized.

NOTICE: This device complies with part 15 of the FCC Rules. Operation is subject to the following two conditions:

1. This device must not cause harmful interference, and
2. this device must accept any interference received, including interference that may cause undesired operation.

ISED Notice (Canada)

This device contains licence-exempt transmitter(s)/receiver(s) that comply with Innovation, Science and Economic Development Canada's licence-exempt RSS(s). Operation is subject to the following two conditions:

1. this device may not cause interference, and
2. this device must accept any interference, including interference that may cause undesired operation of the device.

This equipment complies with Canada radiation exposure limits set forth for an uncontrolled environment. This equipment should be installed and operated with minimum distance of 20 cm between the radiator and your body. This transmitter must not be co-located or operating in conjunction with any other antenna or transmitter.

Privacy notice

If the on-board computer is sent to Bosch Service because it requires servicing, the data stored on the on-board computer may be transmitted to Bosch.

Congratulations

Congratulations on purchasing your eBike computer.

Nyon controls your eBike and reliably displays all your key ride data.

- eBike on-board computer with separate operating unit
- eBike, navigation, fitness and internet functions
- Can be connected via *Bluetooth*[®] to a heart rate monitor
- Wi-Fi connection to the **Bosch eBike Connect** portal

Updates

Nyon's range of functions is always being expanded. Keep your **Bosch eBike Connect** smartphone application up to date.

In addition to the functions shown here, changes to software relating to troubleshooting and functional enhancements may be introduced at any time.

Product Description and Specifications

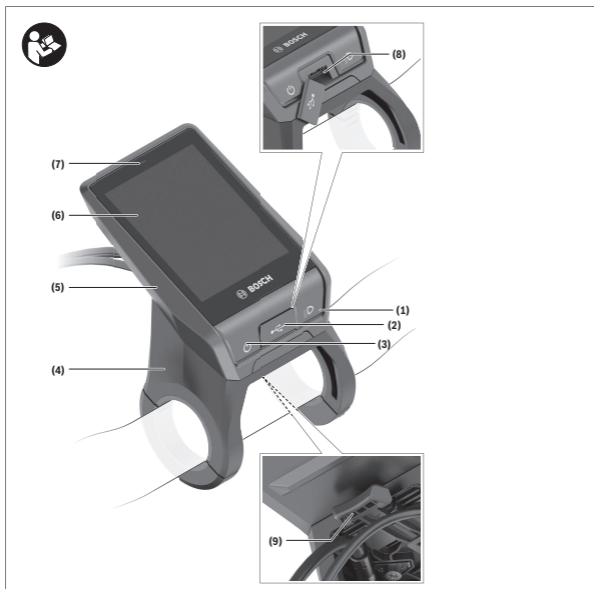

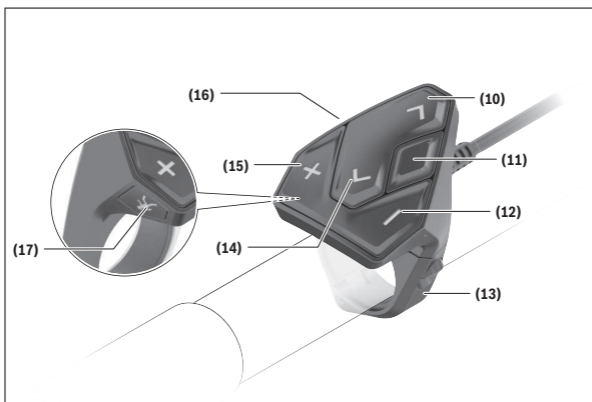

Product Features

All illustrations of bike parts except for the drive unit, on-board computer including operating unit, speed sensor and the corresponding holders are schematic and may differ on your eBike.

- (1)** Bike light button
- (2)** Protective cap for USB port
- (3)** On/off button for on-board computer
- (4)** Holder for on-board computer^{A)}
- (5)** On-board computer
- (6)** Display (touch-sensitive)
- (7)** Brightness sensor
- (8)** USB port
- (9)** Release mechanism
- (10)** Button for next page
- (11)** Select button
- (12)** Button for decreasing the assistance level
- (13)** Holder for operating unit

- (14)** Button for previous page
 - (15)** Button for increasing the assistance level
 - (16)** Operating unit
 - (17)** Start/push assistance button **WALK**
- A) For mounting on the handlebars, custom solutions are possible even without the use of the handlebar clamps.

Intended Use

The **Nyon (BUI350)** on-board computer is designed to control Bosch eBike systems and display cycling data.

In addition to the functions outlined here, changes to software relating to troubleshooting and functional modifications may be introduced at any time.

To find out more, visit: www.Bosch-eBike.com.

Instructions on how to use the app and the portal can be found in the online operating instructions at www.Bosch-eBike.com.

The **Nyon (BUI350)** on-board computer is only intended as a navigation system for bicycles and is not suitable for other means of transport (e.g. hikers or vehicle drivers).

Technical Data

On-board computer		Nyon
Product code		BUI350
Total internal memory	GB	8
Max. USB port charging current (output)	mA	1500
Max. USB port charging voltage	V	5
USB charging cable		1 270 016 360
Operating temperature	°F	23 to 104
Storage temperature	°F	50 to 104
Charging temperature	°F	32 to 104
Internal lithium-ion battery	V mAh	3.7 1000
Protection rating		IP x5
Supported Wi-Fi standards		802.11b/g/n (2.4 GHz)
Weight, approx.	lbs	0.44
Wi-Fi		
– Frequency	MHz	2400–2480
– Transmission power	mW	< 100

On-board computer**Nyon***Bluetooth®*

- Frequency	MHz	2400-2480
- Transmission power	mW	< 10

Assembly

- ▶ **Deactivate and remove the on-board computer if you are fitting or working on the holder.** This avoids malfunctions/misuse.
- ▶ **Deactivate and remove the on-board computer if you are fitting or removing the securing screw.** This avoids malfunctions/misuse.

Inserting and removing the on-board computer

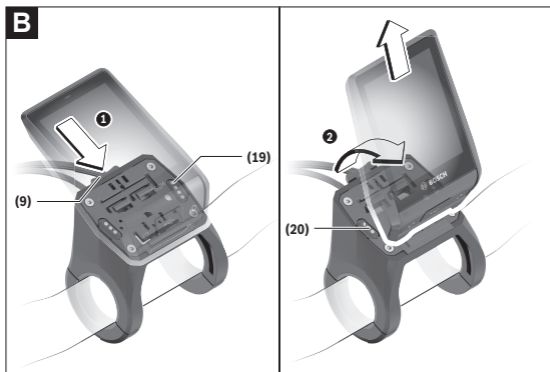
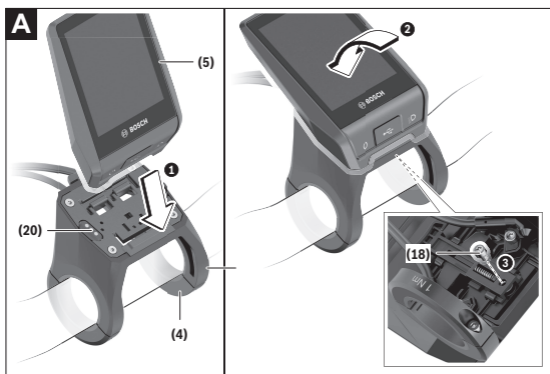

- (4)** Holder for on-board computer^{A)}
- (5)** On-board computer
- (9)** Release mechanism
- (18)** Locking screw for on-board computer

(19) Drive unit contacts**(20)** Operating unit contacts

- A) For mounting on the handlebars, custom solutions are possible even without the use of the handlebar clamps.

To **insert** the on-board computer **(5)**, first fit the lower section into the holder **(4)** and then press it forward until you can feel that the on-board computer is fixed in place. Make sure that the on-board computer is firmly fixed in place.

To **remove** the on-board computer **(5)**, press on the release mechanism **(9)** and take out the on-board computer from above.

► **When you park up the eBike, remove the on-board computer.**

It is possible that the release mechanism may become jammed by a screw. To rectify this, remove the holder **(4)** from the handlebars. Put the on-board computer in the holder. Screw the locking screw **(18)** (M3 thread, 5 mm long) from below into the corresponding thread in the holder. Mount the holder back on the handlebars.

Note: The locking screw is not designed to prevent theft.

Operation

Setting up the eBike system

Requirements

The eBike system can only be activated when the following requirements are met:

- A sufficiently charged eBike battery is inserted (see battery operating instructions).
- The on-board computer is properly inserted in the holder.
- The battery of the on-board computer must be sufficiently charged.

Switching the eBike system on/off

The following options are available for **switching on** the eBike system:

- Once the on-board computer and the eBike battery are fitted, briefly press the on/off button **(3)** on the on-board computer.
- With the on-board computer inserted, press the on/off button on the eBike battery (bicycle manufacturer-specific solutions are possible when there is no access to the battery on/off button; see the operating instructions from the bicycle manufacturer).

The drive is activated as soon as you start pedaling (except for in the push assistance function or with the assistance level **OFF**). The motor output depends on which assistance level is set on the on-board computer.

As soon as you stop pedaling when in normal operation, or as soon as you have reached a speed of **20/28 mph**, the eBike drive unit switches off the assistance. The drive is automatically re-activated as soon you start pedaling again and the speed is below **20/28 mph**.

The following options are available for **switching off** the eBike system:

- Press the on/off button **(3)** of the on-board computer for at least three seconds.
- Switch off the eBike battery using its on/off button (some bicycle manufacturer-specific solutions prevent access to the battery on/off button; see the bicycle manufacturer operating instructions).

Note: This will place the **Nyon (BUI350)** into standby mode.

- Remove the on-board computer from its holder.

If no power is drawn from the eBike drive for about 10 minutes (e.g. because the eBike is not moving) and no button is pressed on the on-board computer

or the operating unit of the eBike, the eBike system, and therefore also the battery, will switch off automatically to save energy.

This will place the **Nyon (BUI350)** into standby mode.

Standby mode

You can put your on-board computer in standby mode, which allows the on-board computer and system to start up quicker when required.

The standby mode can be activated as follows:

- Press and hold the on/off button **(3)** of the on-board computer for 1 to 3 seconds, making sure not to exceed 3 seconds.
- Wait for 10 minutes until the system switches off.
- Switch off the rechargeable battery via the on/off button of the battery.

Standby mode is ended if you press and hold the on/off button **(3)** of the on-board computer for 1 second.

Standby mode is ended and the on-board computer switches off automatically if the state of charge of the on-board computer battery is less than 75 %. In any event, the on-board computer will be switched off at the latest when its internal clock reaches midnight (00:00).

If **Nyon (BUI350)** cannot be switched on or does not work properly, press and hold the on/off button (approx. 15 s). This could rectify the error.

Energy supply of the on-board computer

If the on-board computer is in the holder **(4)**, a sufficiently charged eBike battery is inserted into the eBike and the eBike system is switched on, then the on-board computer battery is powered and charged by the eBike battery.

If the on-board computer is removed from the holder **(4)**, the power is supplied by the on-board computer battery. If the on-board computer battery's charge is running low, a warning message appears on the display.

Color of the indicator	Meaning
Green	The on-board computer battery is over 30 % charged.
Orange	The on-board computer battery is charged between 15 % and 30 %.
Red	The on-board computer battery is less than 15 % charged.

To charge the on-board computer battery, put the on-board computer back in the holder **(4)**. Note that if you are not charging the eBike battery, the eBike system will automatically switch off after 10 minutes if it is not activated. If this happens, the on-board computer battery will also stop charging.

You can also charge the on-board computer via the USB port **(8)**. To do this, open the protective cap **(2)**. Use a Micro USB cable to connect the USB port on the on-board computer to a commercially available USB charger (not included with the product as standard) or to the USB port of a computer (max. **5 V** charging voltage; max. **1500 mA** charging current).

If the on-board computer battery is not recharged, the date and time will be retained for approx. six months.

Note: To maximize the lifespan of the on-board computer battery, it should be recharged for one hour every three months.

Following use, the USB port must be carefully resealed with the protective cap **(2)**.

A USB connection is not a watertight plug connection. When cycling in wet conditions, ensure no external devices are connected and that the USB port is fully covered by the protective cap (2).

It is not possible to charge external devices via the USB port.

Battery Charge Indicator

The battery charge indicator of the eBike battery **g** (see "**<Ride Screen>**", page English – 39) can be read in the status bar. The eBike battery's state of charge is also indicated by the LEDs on the eBike battery itself.

Color of the indicator	Meaning
White	The eBike battery is over 30 % charged.
Yellow	The eBike battery is charged between 15 % and 30 %.
Red	The eBike battery is charged between 0 % and 15 %.
Red + !	The capacity for assisting the drive has been used up, and assistance is switched off. The remaining capacity will be provided for the bike lights and the on-board computer.

If the eBike battery is being charged on the bike, a corresponding notification will be displayed.

If the on-board computer is removed from the holder **(4)**, the state of charge that was last displayed for the battery is saved.

Starting operation of the on-board computer

- ▶ **Prior to initial start-up, remove the protective film from the display to guarantee that the on-board computer is fully functional.** If the protective film remains on the display, this can impact the functionality/performance of the on-board computer.
- ▶ **Full functionality cannot be guaranteed for the on-board computer if protective films are used on the display.**

The Nyon is supplied with a partially charged battery. Before the first use, the Nyon battery must be fully charged via the USB port or via the eBike system.

It is possible to set off within a short duration (approx. 4 seconds) of switching on the on-board computer. During the subsequent period, the on-board computer will continue loading the complete operating system in the background.

Note: When you switch on the on-board computer for the first time, the on-board computer may require a longer period of time before it is ready for travel.

If the on-board computer is connected to a Wi-Fi network, the user will be informed about the existence of a new update where applicable. Make sure to download the update and install the latest version.

Creating a user ID

In order to be able to use all the functions of the on-board computer, you must register online.

With a user ID, you can analyze your ride data, plan offline routes and transfer these routes to the on-board computer.

You can set up a user ID via your **Bosch eBike Connect** smartphone app or simply at www.eBike-Connect.com. Enter the details required for registration. The **Bosch eBike Connect** smartphone app is available to download free of charge from the App Store (for Apple iPhones) or from the Google Play store (for Android devices).

Connecting the on-board computer to the portal

The on-board computer can be connected to the portal via a Wi-Fi connection.

Note: The on-board computer does not support the use of router channels 12 and 13. If your router is fixed to channel 12 or 13, these channels are not displayed in the list of available networks on the on-board computer. If necessary, adjust the settings on your router accordingly in order to connect the on-board computer to your network.

To do this, proceed as follows:

- Press **<Login>** on the **<Status Screen>**.
- Select **<WiFi>**.
- Select a network.
- Enter your username and password.

Once a connection has been successfully established, all data that you have shared on your profile in the portal will be synchronized with the on-board computer.

Connecting the On-Board Computer with the Bosch eBike Connect App

Follow these steps to establish a connection to your smartphone:

- Load the app.
- Select the tab **<My eBike>**.
- Select **<Add new eBike device>**.
- Add **Nyon (BUI350)**.

The app will then display an instruction to press and hold the bike lighting button **(1)** on the on-board computer for 5 seconds.

Press and hold the button **(1)** for at least 5 seconds. The on-board computer automatically activates the *Bluetooth® Low Energy* connection and switches to pairing mode.

Follow the instructions on the screen. Once pairing is complete, the user data is synchronized.

Note: The *Bluetooth®* connection does not need to be activated manually.

Setting the assistance level

On the operating unit **(16)**, you can set the level of assistance you want the eBike drive to provide you with while pedaling. The assistance level can be changed at any time, even while cycling.

Note: In some models, the assistance level may be preset and cannot be changed. There may also be fewer assistance levels available than stated here.

The following assistance levels are available as a maximum:

- **OFF:** Motor assistance is switched off. The eBike can just be moved by pedaling, as with a normal bicycle. The push assistance cannot be activated at this assistance level.
- **ECO:** Effective assistance with maximum efficiency, for maximum range
- **TOUR:** Steady assistance, long range for touring
- **SPORT/eMTB:**
 - SPORT:** Powerful assistance, for mountain biking and for cycling in urban traffic
 - eMTB:** Optimum assistance whatever the terrain, rapid acceleration when starting from a standstill, improved dynamics, top performance (**eMTB** is only available in combination with drive units BDU250P CX, BDU365, BDU450 CX and BDU480 CX. This also requires a software update.)
- **TURBO:** Maximum assistance even at high pedaling speeds, for biking sports

To **increase** the assistance level, press the **+** button (**15**) on the operating unit repeatedly until the required assistance level appears on the indicator. To **decrease** the assistance level, press the **-** button (**12**).

The requested motor output is shown on the display **j**. The maximum motor output depends on the selected assistance level.

Switching the push assistance on/off

The push assistance aids you when pushing your eBike. The speed of this function depends on the selected gear and can reach a maximum of **3.7 mph**. The lower the selected gear, the lower the speed of the push assistance function (at full power).

► **The push assistance function must only be used when pushing the eBike.** There is a risk of injury if the wheels of the eBike are not in contact with the ground while using the push assistance.

To **activate** the push assistance, briefly press the **WALK** button on your on-board computer. After activation, press the **+** button within 3 s and keep it pressed. The eBike drive is switched on.

Note: The push assistance cannot be activated at assistance level **OFF**.

The push assistance is **switched off** as soon as one of the following occurs:

- You release the **+** button;
- the wheels of the eBike are locked (e.g. by applying the brakes or hitting an obstacle);
- the speed exceeds **3.7 mph**.

The push assistance function is subject to local regulations; the way it works may therefore differ from the description above. It can also be deactivated.

Switching bicycle lights on/off

On the model in which the lighting is powered by the eBike system, the front and rear lights can be switched on and off at the same time via the on-board computer using the bike light button **(1)**.

Before starting each journey, check that your bike lights are working correctly.

If the lighting is switched on, the bike light indicator **f** lights up in the status bar of the display.

Switching the bike lights on and off has no effect on the backlighting of the display.

Lock (premium function)

The Lock function is available to purchase from the **<Shop>** in the eBike Connect app. Once the Lock function has been set up and the Lock has been activated by removing the on-board computer, the eBike drive unit assistance is deactivated. It can only be activated using the on-board computer associated with the eBike.

The Lock function is linked to your **user account**, which you can use to log into the **eBike Connect app**. The account allows you to use the Lock function with an on-board computer, which in turn can be used to activate the function on up to four eBikes.

Note that 2 hours must have passed in between any 2 activations of the Lock function.

Warning! If you attempt to change a setting in the app, the on-board computer or the portal that could have negative consequences in combination with the Lock function (e.g. deleting your eBike or user account), you will be shown warning messages beforehand. **Please read through these thoroughly and adhere to the warnings that are issued (e.g. before deleting your eBike or user account).**

Compatibility

The Lock function is compatible with these Bosch eBike product lines:

Drive unit	Product line
BDU3xx	Active Line, Active Line Plus, Performance Line
BDU4xx	Performance Line Speed, Cargo Line, Cargo Line Speed, Performance Line CX

Setting up the Lock function

In order to be able to set up the Lock function, the following conditions must be fulfilled:

- You have purchased the Lock function.
- The on-board computer is situated in the holder on the eBike.
- The on-board computer is connected to the smartphone via *Bluetooth*[®].
- The smartphone is connected to the Internet.

Go to the **<My eBike>** menu item in your eBike Connect app and set up the Lock function for your eBike by sliding the control **<Lock feature>** to the right.

From now on, you can deactivate the assistance from your drive unit by removing the on-board computer. The drive unit assistance can only be reactivated with the on-board computer that was used in the setup.

Even with the Lock function activated, you can continue to use your eBike without assistance from the drive unit.

How it works

In combination with the Lock function, the on-board computer functions similarly to a key for the drive unit. The Lock function is activated and deactivated by respectively removing or inserting the on-board computer. The status of the Lock function is indicated by a padlock symbol that appears on the display of the on-board computer for approx. three seconds following its insertion.

Remove the on-board computer from its holder whenever you are away from the eBike so that the Lock function can fulfill its intended purpose.

If the on-board computer used in setting up the Lock function is not inserted on your eBike, the drive unit will not provide any assistance. However, you can still continue to use your eBike without assistance.

Note: The Lock function alone does not provide adequate theft protection; it is simply a supplement to a mechanical lock. The Lock function does not provide any form of mechanical lock for the eBike. Only the assistance from the drive unit is deactivated.

If you wish to give other users temporary or permanent access to your eBike, you will need to deactivate the Lock function in the eBike Connect app.

If you remove the on-board computer, the drive unit will emit a “Lock” sound (i.e. an audio signal that is played **once**) to indicate that the assistance from the drive unit is switched off.

Note: The audio signal will only be played if the system is switched on.

If you reinsert the on-board computer, the drive unit will emit two “Unlock” sounds (i.e. an audio signal that is played **twice**) to indicate that the assistance from the drive unit is enabled again.

The “Lock” sound will help you determine whether or not the Lock function on your eBike is active. The audio signal is activated by default, but it can be deactivated under **<My eBike>** by selecting the lock symbol below your eBike.

In the eBike Connect app, the Lock function under **<My eBike>** is indicated with a lock symbol next to the bikes.

Attention: The lock symbol is only shown for eBikes that are suitable for the Lock function. Note the information in the section on compatibility.

Please contact your bike dealer if any of the following occurs:

- The Lock function can no longer be set up or switched off
- Your eBike Connect account has been deleted or deactivated, yet the Lock function has been set up and remains active.

Replacing eBike components and the Lock function

Replacing the smartphone

1. Install the eBike Connect app on the new smartphone.
2. Log in with **the same** account that was used to activate the Lock function.
3. Connect your smartphone with the on-board computer while the on-board computer is attached.

4. The Lock function is displayed as set up and active in the eBike Connect app.

Replacing the on-board computer

1. Connect your smartphone with the on-board computer while the on-board computer is attached.
2. The Lock function is displayed as set up and active in the eBike Connect app.

Replacing the Drive Unit

1. The Lock function is displayed as set up and deactivated in the eBike Connect app.
2. Activate the Lock function by sliding the **Lock function** control to the right.

Activity tracking

In order to record activities, you must be registered with and logged into the eBike Connect portal or the eBike Connect app.

To record activities, you must consent to the storage of your location data either in the portal or in the app. Without this, your activities will not be shown in the portal or the app. The position is only recorded if you as a user are logged into the on-board computer.

Once synchronization is complete, the activities will already be displayed in the app and in the portal during the journey.

eShift (optional)

eShift is the integration of electronic gear shifting systems into the eBike system. The eShift components are electrically connected to the drive unit by the manufacturer. The separate operating instructions describe how to operate the electronic gear-shifting systems.

Software Updates

If **Nyon (BUI350)** is connected to the Wi-Fi, it automatically checks whether a newer version of the software is available. If a software update is available, a notification will inform the user of this. Alternatively, the user can search for updates manually under **<System Settings>**.

Notes on cycling with the eBike system

Taking care of your eBike

Please observe the operating and storage temperatures of the eBike components. Protect the drive unit, on-board computer and battery against extreme temperatures (e.g. from intense sunlight without adequate ventilation). Extreme temperatures can cause the components (especially the battery) to become damaged.

Keep the screen of your Nyon clean. Dirt can cause faulty brightness detection. The day/night switchover function in the navigation mode may function incorrectly.

Abrupt changes in environmental conditions can cause the window to steam up from the inside. The temperature will equalize after a short period and the condensation will subsequently disappear.

The Nyon operating system

The Nyon operating system consists of three components:

1. The Nyon on-board computer with operating unit
2. The **Bosch eBike Connect** smartphone app
3. The www.ebike-connect.com online portal

A number of settings and functions can be administered or used on all components. Some settings and functions can only be accessed or operated via specific components. Data is automatically synchronized if a *Bluetooth*[®]/Internet connection has been established. The following table provides an overview of the possible functions.

Functions of the online portal

③

Functions of the smartphone app

②

Functions of the on-board computer

①

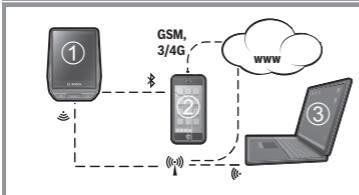

Login	✓	✓	✓
Registration		✓	✓
Modification of settings	✓	✓	✓
Collection of trip data	✓		
Real-time display of trip data	✓		
Processing/analysis of trip data		✓	✓
Creation of user-defined displays	✓		
Indication of current location	✓ ^{A)}	✓ ^{A)}	✓
Navigation	✓		
Route planning	✓	✓	✓
Indication of remaining range (Circle around current location)	✓		
Training effect in real time	✓		
Trip overview		✓	✓
Purchase of premium functions		✓	

A) GPS required

Premium functions

The standard functions of the **Nyon (BUI350)** operating system can be supplemented through the purchase of **premium functions** via the App Store for Apple iPhones or the Google Play store for Android devices.

In addition to the free **Bosch eBike Connect** app, premium functions are available for a fee. A detailed list of the additional apps that are available can be found in the online operating instructions at www.Bosch-eBike.com.

User management

The first user to log in on the on-board computer is automatically set as the owner. If this user logs out and a different user logs in, the new user is assigned a guest role.

The on-board computer must be restored to its factory settings in order to set a new owner. The first user to log in after the reset is automatically set as the new owner.

Owner rights

Even if the owner logs out, their activity data remains saved until the next synchronization.

Note on the lock function: Only the owner of the Nyon can activate and deactivate the lock function. When the lock function is activated, a guest with the same Nyon as the owner can still use the bike.

Guest rights

Once an owner is set on the Nyon, every additional user who logs in is automatically considered a guest.

When the guest logs out, all activity data that could not be synchronized before the logout will automatically be deleted.

Displays and settings of the on-board computer

Note: All interface displays and texts on the following pages correspond to the release status of the software. The interface displays and texts may change slightly following a software update.

The Nyon has a touch-sensitive screen. The individual screens can be navigated between by swiping right or left. Status screen functions or submenus can be called up by pressing the corresponding buttons.

The Nyon has standard screens and predefined screens. The user can also create their own custom screens. The order and number of screens can be set by the user. Max. 25 tiles can be used for the screens. The description of the screens in these operating instructions corresponds to the basic configuration that is provided upon delivery of the on-board computer.

The standard screens are:

- **<Status Screen>**
- **<Ride Screen>**
- **<Trip Data Screen>**
- **<Map Screen>**
- **<Analysis Screen>**

The predefined screens include:

- **<Fitness Screen>**
- **<eMTB Screen>**
- **<Basic Screen>**

You can use the **< (14)** and **> (10)** buttons to switch between the different pages of riding values (even while riding). This way, you can keep both hands on the handlebars while cycling.

You can use the **+ (15)** and **- (12)** buttons to increase or decrease the assistance level.

The **<Settings>** that can be accessed via the **<Status Screen>** cannot be changed while riding.

<Status Screen>

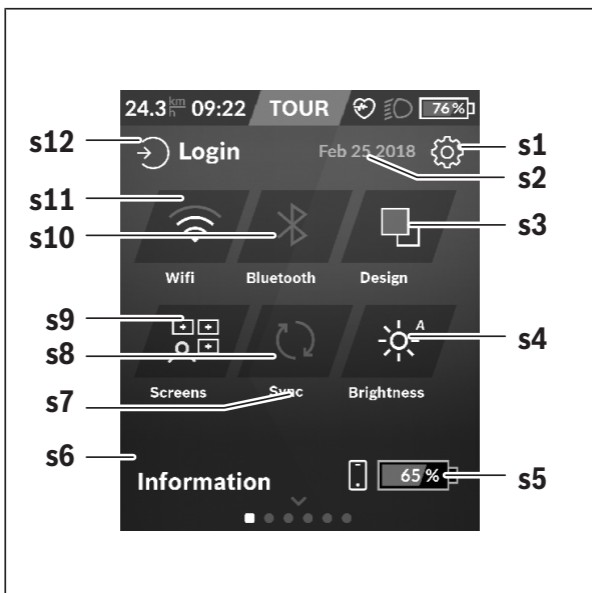

s1 Button for **<Settings>**

s2 Date

s3 **<Design>**

Here, the background can be changed from light to dark.

s4 Button for **<Brightness>**

Here, a brightness setting can be selected from the following: 25 % | 50 % | 75 % | 100 % | Auto.

s5 Smartphone battery charging

s6 **<Information>**

Events that are currently occurring are shown here (e.g. map download).

- s7** Time of last synchronization
- s8** Button for synchronization
- s9** Button for **<Screens>**
Via this button, the order of screens and their content can be adjusted.
- s10** Button for **<Bluetooth>**
Tap: Activate/deactivate
Press and hold: Quick access to the *Bluetooth*® menu
- s11** Button for **<WiFi>**
Tap: Activate/deactivate
Press and hold: Quick access to the Wi-Fi menu
- s12** **<Login>**
Here, the user can connect with their ID.

<Settings>

You can access the settings menu via the status screen. The **<Settings>** cannot be accessed or changed while riding.

Tap the **<Settings>** button and select the required setting/submenu. Press the back arrow in the header to move to the previous menu. Press the **x** symbol (in the right of the header) to close the settings menu.

You can find the following superordinate sections on the first level of settings:

- **<Map Settings>**
Via **<Map Settings>**, the map display format (2D/3D) can be selected, downloaded maps and map updates can be reviewed, and recommended maps can be downloaded.
- **<My eBike>** – Your eBike settings:
You can reset the counters (such as the number of kilometers traveled that day or average values) to zero either automatically or manually, and you can reset the range. You can change the wheel circumference value that was preset by the manufacturer by $\pm 5\%$. If your eBike features **eShift**, you can also configure your eShift system here. The bike retailer can schedule the service based on a mileage and/or a time period. The bike component page displays the serial number and hardware and software versions for each component, in addition to other key data that is relevant for the components.

– **<Screen Management>**

You can select this menu item to adjust the screen and tile contents to your personal requirements.

– **<Connections>**

Here, the *Bluetooth*[®] and Wi-Fi connections can be adjusted. To be able to use the heart rate display, you must add either the **<Fitness Screen>** from the predefined screens or a heart rate tile to your standard screens. Once you are connected, the heart symbol on the tile turns blue.

Recommended heart rate monitors:

- Polar H7
 - Polar H10 Heart Rate Sensor
 - Runtastic Heart Rate Combo Monitor
 - Wahoo TICKR Heart Rate Monitor
 - BerryKing Heartbeat chest strap
 - BerryKing Sportbeat armband
- May be compatible with other devices.

– **<My Profile>**

The data belonging to the active user can be viewed here.

– **<System Settings>**

You can display the speed and distance in kilometers or miles, display the clock in 12- or 24-hour format, adjust the time, date and time zone and select your preferred language. You can reset the Nyon to its factory settings, run a software update (if available) and choose between a black and white design.

– **<Information>**

Information on FAQ (frequently asked questions), certification, contact information, information on licenses. You can find a detailed description of each parameter in the online operating instructions at www.Bosch-eBike.com.

<Ride Screen>



- a** Speed
- b** Unit of speed
- c** Time^{A)}
The current time is shown according to the selected time zone. This is set automatically via GPS.
- d** Assistance level
The screen is colored according to the assistance level that is set.
- e** Connection to heart rate monitor
This also functions as a placeholder for additional events. An indicator is displayed whenever the respective event occurs (e.g. connection to a smartphone)

- f** Bike lighting
This symbol is displayed whenever the bike lights are switched on.
- g** eBike battery charging
- h** Range information^{B)C)}
- i** Distance traveled
- j** Motor output
- k** Your output
- A) On eBikes with ABS, the time is replaced by the letters **((ABS))** during system start-up or if there is a fault with the ABS.
- B) When the navigation system is **active**, a destination flag will be shown at the end of the scale and the remaining distance to the destination will be displayed. If the eBike battery has sufficient capacity, the right-hand section of the scale will be shown in green. If the right-hand section of the scale is shown in orange or red, it is either uncertain or impossible that you will reach your destination with motor assistance at the assistance level you have currently selected. If you select a lower assistance level, the remaining battery capacity may still be sufficient to allow you to reach your desired destination.
- C) When the navigation system is **inactive**, the number of kilometers traveled will be shown on the left, and the range on the right.

The indicators for **a through to g** form the status bar and are shown on every page.

If the on-board computer is removed from the holder, the status bar will change:



- l** On-board computer battery charging
If a *Bluetooth*[®] and/or Wi-Fi connection is present, this will be displayed in the middle of the corresponding icons.
- g** eBike battery charging
Current state of charge of the eBike battery

<Trip Data Screen>

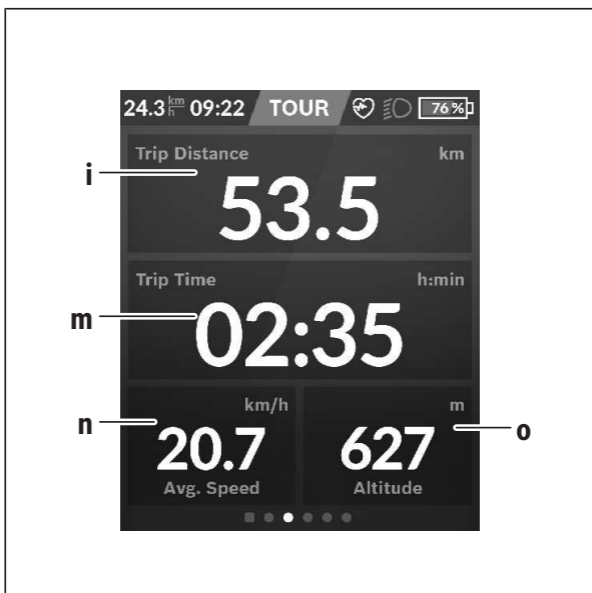

- i** <Trip Distance>
Indicator for distance traveled
- m** <Trip Time>
Indicator for trip duration
- n** <Avg. Speed>
Indicator for average speed
- o** <Altitude>
Indicator for altitude

<Map Screen>

The navigation system draws on map material that is based on OpenStreetMap (OSM).

Whenever you switch on Nyon, it will begin with a satellite search to enable it to receive GPS signals. Once enough satellites have been found, the location point will change color from gray to blue. In unfavorable weather conditions or locations, the search for satellites may take a little longer. If no satellites have been found after an extended period of time, Nyon will restart.

When searching for satellites for the first time, the process can take several minutes.

In order to achieve the best possible positional accuracy, the first satellite search should be carried out outdoors. Ideally, you should remain stationary for a few minutes while this takes place, even if your position has already been found.

Once Nyon has determined your location, this will be shown to you on the map. To **zoom in** to a section of the map, place **two** fingers on the touchscreen and spread them apart. To **zoom out** of a section of the map, place two fingers on the touchscreen and bring them together. To **move around** the map, simply place two fingers on the touchscreen and move them across the map. To **select a destination**, press and hold a finger against a location on the map.

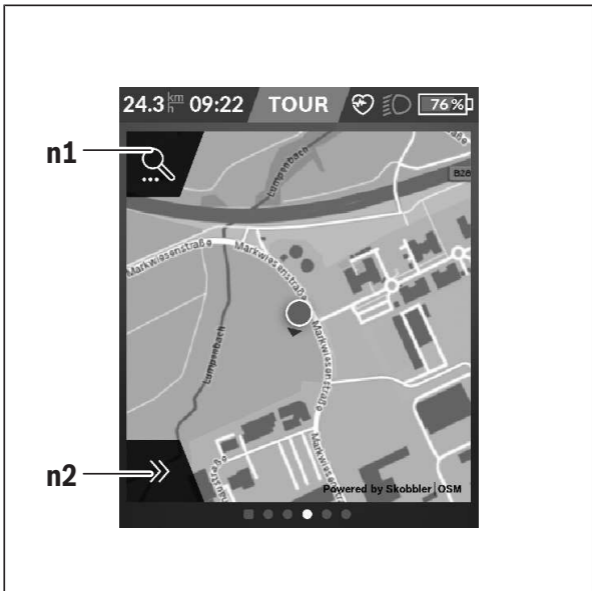

n1 Navigation search

n2 Navigation functions

Using the navigation functions **n2**, you can select your destinations and ensure that these can be reached with the current state of charge.

While the navigation system is active, the user is informed about the current assistance mode they are using and whether they are able to reach their destination with the current eBike battery state of charge.

The circle around the user's position shows how far they are able to travel with the current level of battery charge, taking into account

the current assistance level and the terrain to be covered. Adjusting the assistance level will adjust the radius of the circle accordingly.

If you select the navigation search **n1**, you will be shown the following menu:

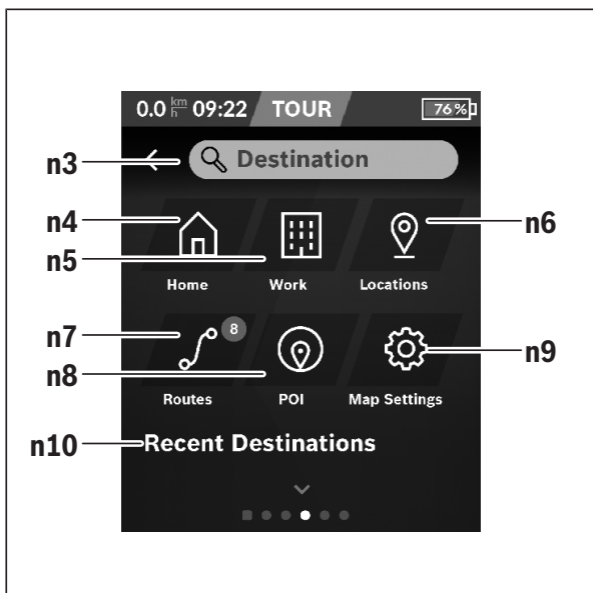

n3 Input field **<Destination>**

Here, you can enter the address of your destination or a point of interest (e.g. a restaurant). Depending on the input, all potential addresses within a radius of 100 km will be shown to you.

n4 Button for **<Home>**

By selecting this button, you will be directed to your home address.^{A)}

n5 Button for **<Work>**

By selecting this button, you will be directed to your workplace address.^{A)}

n6 Button for **<Locations>**

Select this button to view the locations you have saved that have been synchronized from the app or the portal.

n7 Button for **<Routes>**

The routes that have been saved and subsequently synchronized are shown in the portal.

n8 Button for **<POI>**

Select this button to view destinations of general interest, such as restaurants or shopping facilities.

n9 Button for **<Map Settings>**

By selecting this button, you can adjust how the maps are displayed or manage your maps.

n10 **<Recent Destinations>**

The most recent routes and locations are listed here.

A) Data from the app and the portal is imported and displayed.

If you have entered a destination, the quickest available route (**<Fast>**) will be shown to you first. You can also select the scenic (**<Scenic>**) or the MTB route (**<MTB>**). Alternatively, you can receive directions to take you home (when you have logged your home address in the portal), select one of your recent destinations or choose from saved locations and routes.

The remaining range of the battery is calculated and displayed according to the topographical conditions. The calculation of the topographical range extends to a maximum of 100 km.

If you have imported or planned GPX routes via the online portal, these will be transmitted to your Nyon via *Bluetooth*[®] or a Wi-Fi connection. You can begin these routes as and when necessary. If you are located in the vicinity of the route, you can be directed to the start of the route or begin following the navigation system immediately.

In temperatures below 0 °C, significant deviations must be taken into account with regard to height measurement.

Active Navigation

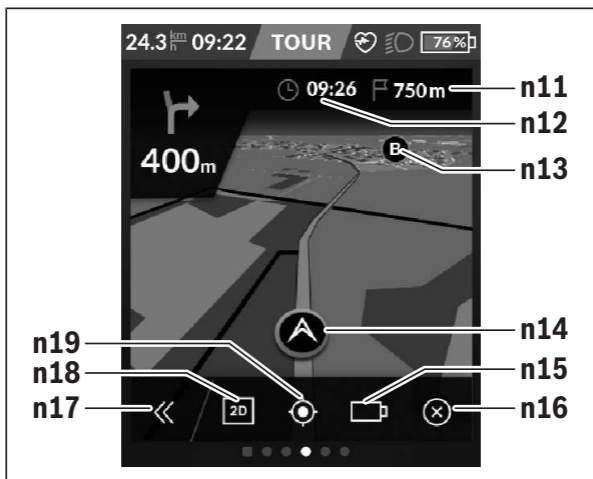

The following figure shows an example of active navigation with explanations of the depicted symbols.



- n11** Distance to the destination
- n12** Arrival time
- n13** Destination
- n14** Current position
- n15** Range indicator battery
- n16** End active navigation
- n17** Open and close panel (back to search)
- n18** Switch between 2D and 3D view
- n19** Center view (only visible when the map has been moved)

Range display

When you have started navigation, the system shows you whether the current battery charge level will be enough to reach your destination. The color and appearance of the range indicator **n15** change according to the charge level that the eBike battery will have when you reach your destination. The following table provides an overview of the possible displays relating to the eBike battery charge level.

Appearance	Color	eBike battery charge level at destination
	Green	> 30 %
	Orange	15 % ... 30 %
	Red	7 % ... 15 %
	Red	< 7 %

<Analysis Screen>



- p** <Riding Mode Usage>
Indicator for use of different riding modes
- q** <Max. Speed>
Indicator for maximum speed

- r** **<Ascent>**
Indicator for gradient
- s** **<Avg. Power>**
Indicator for relationship of own output compared to motor output

Creating custom screens

In order to incorporate predefined screens or create new screens, navigate to the status screen and select the adjustment **s9** button. Four icons are shown to you in the footer that allow you to make an adjustment.

As an option, the function can also be started via **<Settings>** → **<Screens>**.

The following options are available to you:

- Move screens
- Create new screens
- Delete screens
- Add predefined screens

<Fitness Screen> (predefined screen)

- t** **<My Power>**
Indicator for own output
- u** **<Cadence>**
Indicator for cadence
- r** **<Heartrate>**
Indicator for heart rate
- v** **<Calories>**
Indicator for kilocalories burned

<eMTB Screen> (predefined screen)

- r** **<Slope>**
Indicator for gradient
- o** **<Altitude>**
Indicator for altitude
- w** **<Altitude Graph>**
Indicator for elevation profile
- x** **<Max. Slope>**
Indicator for maximum gradient
- y** **<Ascent>**
Indicator for gradient

<Basic Screen> (predefined screen)

- i** **<Trip Distance>**
Indicator for distance traveled
- m** **<Trip Time>**
Indicator for trip duration
- a** **<Avg. Speed>**
Indicator for average speed

<Quick Menu>

Selected settings are displayed on the quick menu. These settings can also be changed while riding.

You can access the quick menu via the select button **(11)**. You can use the **< (14)** and **> (10)** buttons to switch between the submenus. The submenu items can be selected with the **+ (15)** and **- (12)** buttons.

From the **<Status Screen>**, you are unable to reach the **<Quick Menu>**.

The following submenus can be changed via the **<Quick Menu>**:

- **<Trip Data>**
Via this submenu, you can reset all data on the distance traveled so far to zero.
- **<Select Destination>**
Via this submenu, you can save your current position, return to a saved position, or receive directions to take you home.
- **<Map Zoom>**
Via this submenu, you can zoom in or out of a section of the map.
- **<Brightness>**
Via this submenu, a brightness setting can be selected from the following:
25 % | 50 % | 75 % | 100 % | Auto.
- **<Design>**
Via this submenu, you can select a light or dark background.
- **<eShift>** (optional)
Via this submenu, you can set the cadence.
- **<Custom Riding Modes>** (premium function, can be obtained from the App Store or Google Play Store)
Via this submenu, you can select individual riding modes.
- **<Quick Menu>**
Via this submenu, you can leave the **<Quick Menu>** again.

Displays and settings of the Bosch eBike Connect smartphone app

A smartphone is not one of the items included. An Internet connection is required to register with a smartphone, which, depending on how the contract has been drafted, may incur costs from your telephone provider. An Internet connection is also required to synchronize data between the smartphone and online portal.

Note: All interface displays and texts on the following pages correspond to the release status of the software. As the software may be updated over the course of the year, it is possible that the interface displays and/or texts may change.

The following description of the eBike Connect app applies to the Kiox (BUI330) and Nyon (BUI27x and BUI350) on-board computers.

Activation of the Bosch eBike Connect Application

To be able to use all eBike Connect functions, a smartphone with the **Bosch eBike Connect** application is required.

Proceed as follows to activate:

1. Open Google Play Store (Android) or the App Store (iOS) on your smartphone.
2. Search for **Bosch eBike Connect**.
3. Install and open the **Bosch eBike Connect** application.
4. Register as described in the next section.











Should you have already registered via the online portal (www.ebike-connect.com), you can also log in directly with your login details.

Registration via Smartphone

- Start the **Bosch eBike Connect** application.
- Select **<Sign up>**.
- Read and accept the General Terms and Conditions and the privacy statement.
- After confirmation, you will receive an e-mail to your specified e-mail address with the contractual provisions.
- Activate your user account by clicking the button in your e-mail.

If the **Bosch eBike Connect** application is active and there is a *Bluetooth*[®] connection to your on-board computer, data is automatically synchronized between the on-board computer and smartphone.

Main Menu of Bosch eBike Connect

Symbol	Menu item	Function
	<Feed>	Under this menu item, you will find an overview of the kilometers ridden in the past month, a display of the last activity that has not yet been completed and current messages.
	<Activities>	The distances you have ridden are displayed under this menu item.
	<Map>	You can plan routes via this menu item. Saved routes are automatically synchronized between the app and the on-board computer (not for BUI330).
	<My eBike>	Via this menu item, you can select your on-board computer and adjust your eBike settings.
	<More>	This button can show you further menu items.
	<Shop>	Via this menu item, you can purchase premium functions that are compatible with your product.
	<Settings>	Via this menu item, you can view and edit your personal data and your data protection and app settings, as well as download maps for offline use of the app.
	<Help>	You can find answers to <FAQs> under this menu item.
	<Imprint>	Under this menu item, you can find the manufacturer contact details.
	<About>	Under this menu item, you can find content including the application version, the Terms of Use, the description of the service and the data protection notice.

<Activities> menu item

Under the <Activities> menu item, you can see the ridden routes that were not previously planned in the online portal (e.g. via Komoot).

After synchronization, your journeys are displayed on the map. The synchronization status is displayed on the on-board computer.

When you select a journey, the route traveled is displayed to you on a map, in addition to the distance, journey duration and average speed. In addition, three further pages are available with driving statistics data.

<Map> menu item

The map displayed here is intended for viewing and destination input, but route tracing – as with Google Navigation, for instance – is not possible.

When you have selected this menu item, your current location will be shown using the GPS function of the smartphone.

You can select saved locations via the search function. You can also enter a destination by clicking on the map.

Once you have entered the destination, you will be offered three different routes (<Fast>, <Scenic> and <Mountain bike>) displaying the elevation profile.

- The <Fast> route shows you the fastest connection from your location to your selected destination while avoiding steeper slopes.
- The <Scenic> route shows you the most scenic connection from your location to your selected destination and avoids main roads.
- The <Mountain bike> route guides you over mostly unpaved trails and offers the best route for a mountain bike (not for eBikes up to 45 km/h).

Note: The different <Fast>, <Scenic> and <Mountain bike> routes may be identical on short routes.

If you are using **Nyon**, the planned route is automatically transmitted to **Nyon** as soon as there is a connection between the app and Nyon.

If you are using **Kiox**, then you transmit the planned route by selecting the button to start the route and confirm with OK once you have read the safety instructions.

In addition to route planning, you can find your previously saved destinations and routes in the search history. Based on your current location, you can also receive directions to take you home or to work.

<My eBike> menu item

Upon initial installation of the app, a connection between the app and the on-board computer is established via this menu item.

To achieve this, select **<Add new eBike device>** and follow the instructions.

Once successfully linked, the currently connected on-board computer and its associated eBike components will be displayed.

The eBikes that were connected with Kiox or Nyon will be displayed.

If the on-board computer has already been fitted on at least two different eBikes, these will be displayed here and can be selected. Otherwise, no selection is possible. For each eBike, the name can be changed or the eBike can be deleted from the selection list.

<Shop> menu item

If you are using **Nyon**, you have the option of expanding the functionality of your on-board computer with the **<Shop>** menu item in terms of premium functions.

<Custom riding modes>

With this extension, four different riding modes can be configured. This means that, for each of the four riding modes, the assistance level of the motor support can be set depending on the speed at four points.

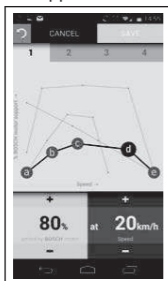

You can configure four different riding modes however you like.

When setting, five definable **checkpoints** or steps are available to you. For the middle three points, you can select any performance assistance required for a certain speed. For the left exterior point, only the performance assistance can be changed (speed is fixed at 0 km/h). For the right interior point,

only the maximum speed can be changed (performance assistance is fixed at 0 %). The speed is plotted on the horizontal x-axis and the performance assistance on the vertical y-axis in percent. If you are satisfied with the definition, save the riding mode. The riding mode is then automatically transmitted to Nyon if there is a *Bluetooth*[®] connection.

Displays and Settings of the Online Portal

Note: All interface displays and texts on the following pages correspond to the release status of the software. As the software may be updated over the course of the year, it is possible that the interface displays and/or texts may change.

The following description of the online portal applies to **Kiox** and **Nyon**.

Online Registration

Internet access is required for online registration.

- Open the **Bosch eBike Connect** online portal at www.ebike-connect.com with your browser.
- Read and accept the General Terms and Conditions and the privacy statement.
- Follow the instructions and complete registration.

Once you have registered, you can log in from this point with your e-mail and password. Alternatively, you can also log in via **Facebook login**. An existing Facebook profile is required for **Facebook login**. The login details from the online portal match the login details of the **Bosch eBike Connect** smart-phone application.

Online Portal Main Menu

Menu item	Function
<Dashboard>	Your recent activities, statistical data, news and tips are displayed under this menu item.
<Route Planning>	You can plan new routes via this menu item.
<Activities>	The distances you have ridden are displayed under this menu item.
<My eBike>	Via this menu item, you can manage your eBike components and create user-defined views.
<Help>	Under this menu item, you can find FAQs, contact information and further information.
	Under this menu item, you can manage your profile.

<Route Planning> menu item

The **<Route Planning>** menu item comprises the following submenus:

- **<Build route>**
- **<Explore>**
- **<My Routes>**
- **<Import GPX track>**

<Build route>

By specifying the start and end point, you can plan a new route. If required, you can add further intermediate destinations by entering the address.

Addresses or coordinates can be entered in decimal format as start and end points or an intermediate destination. Alternatively, an element can be selected from the list of recent destinations, saved locations or points of interest.

On the map, you can add further intermediate destinations by dragging a point from a route. By right-clicking, you can add a new end point or delete existing points. The start and end point as well as the intermediate points on the map can be moved.

You can choose between three different routes (**<Fast>**, **<Scenic>** and **<MTB>**).

- The **<Fast>** route shows you the fastest connection from your location to your selected destination while avoiding steeper slopes.

- The **<Scenic>** route shows you the most scenic connection from your location to your selected destination and avoids main roads.
- The **<MTB>** route guides you over mostly unpaved trails and offers the best route for a mountain bike (**not** for eBikes up to 45 km/h).

The different **<Fast>**, **<Scenic>** and **<MTB>** routes may be identical on short routes.

The currently selected route is displayed on the map. In addition, the uphill/downhill gradient, distance and estimated trip duration of the selected route are displayed.

When you have built your desired route, save it by pressing **<Save>**.

The saved routes and locations are synchronized with the **eBike Connect** app once they have been saved.

In addition, you can plan the route as a round trip (**<Plan as round trip>**).

If you have an S-Pedelec, the online portal offers you only tracks that are suitable for this eBike type.

If you have connected both a normal Pedelec and an S-Pedelec with the account, you can switch between both eBike types in route planning.

If you are using **Nyon**, the planned route is automatically transmitted to **Nyon** as soon as there is a connection between the app and Nyon.

<Explore>

Under the **<Explore>** menu item, tour suggestions for your surrounding area are offered to you through the "Outdooractive" partner.

You can select one or several tours, which you can save under **<My Routes>**.

<My Routes>

All your saved routes can be accessed and changed here.

A route is automatically synchronized if your on-board computer is connected to the Wi-Fi (only with Nyon) or the eBike Connect smartphone app.

<Import GPX track>

GPX files contain a series of location coordinates (waypoints), the sequence of which describes a route. These GPX files can be used for navigation with the Kiox and Nyon on-board computers. GPX files can be created or edited with the corresponding programs.

Using the **<Import GPX track>** button, you can import GPX files of up to 5 MB to the online portal. The GPX files are saved in the background as soon as the on-board computer is connected to the Internet via a smartphone.

With Nyon, the connection can also be established via Wi-Fi. The on-board computers themselves cannot import GPX files directly via a USB connection.

The routability of GPX tracks depends on the level of detail of the OSM maps. Depending on whether there are streets and paths on which you can ride, the following results are possible.

If you are using **Kiox**:

- GPX track is fully routable.
Navigation is only possible if the remaining distance is specified. If Kiox is near the starting point, navigation can be started immediately. If Kiox is further away from the starting point, then you must first make your way to the starting point.
- GPX track is not routable.
The route is statically displayed on Kiox and can be followed by the rider. No distance can be displayed.
- GPX track is partially routable.
If you are using the modified version, the route will be converted into a fully routable track and saved. If you are keeping the original version, the route will be treated like a non-routable track.

If you are using **Nyon**:

- GPX track is fully routable.
As usual, navigation including turn-by-turn directions and the specification of the remaining distance and estimated time of arrival is possible. The turn-by-turn directions can be switched off with the top right button. If Nyon is near the starting point, navigation can be started immediately. If Nyon is further away from the starting point, the rider can receive directions to it.
- GPX track is not routable.
The route is statically displayed on Nyon and can be followed by the rider. No navigational instructions or time calculations can be carried out.
- GPX track is partially routable.
If you are using the modified version, the route will be converted into a fully routable track and saved. If you are keeping the original version, the route will be treated like a non-routable track.

<Activities> menu item

You can see here in the overview a summary of all your previously completed activities. Under the **<Activities>** menu item, you can view individual activities in detail.

After synchronization, your journeys are displayed on the map. The synchronization status is displayed on the on-board computer.

When you select a journey, further statistical data is offered to you in addition to the distance and journey duration. The route traveled is displayed on a map. You can illustrate up to two measurands of the journey in a diagram.

If you have used a chest strap, you will also be shown your heart rate.

Incomplete activities will also be displayed after synchronization.

Under **<Options>**, you have the option of exporting the completed activity into various formats or converting the activity into a route.

If you have connected your account to Facebook, you can share the completed activity with your friends on Facebook.

<My eBike> menu item

Under **<My eBike>**, you can manage your eBike components, and create and adapt custom riding modes (only with Nyon).

<Help> menu item

Under the **<Help>** menu item, you will find a selection of FAQs, contact information, legal information and information on the system and licenses.

Profile menu item



You can adapt your profile under **<My profile>**:

- You can change the e-mail address and password, and adjust your fitness data and personal data under **<My profile>**.
- Here you can also select your preferred language for the portal interface.
- You can delete your account on **eBike Connect**.

Under **<Privacy settings>**, you can influence the collection and control of your personal data. The following setting options are available to you:

- **<Geolocation data>**
Here you can deactivate storage of the location data.
- **<Diagnose and use>**
Here you can control the use of your user data.

– **<Delete all your eBike activities>**

Here you can delete all eBike activities.

Under **<Connected apps>**, you can connect to the apps of Bosch partners, consequently synchronizing your activities with these apps.

Troubleshooting

The components of the eBike system are continuously monitored automatically. If a fault is detected, the corresponding fault code will appear on the on-board computer.

The drive may also be switched off automatically depending on what type of fault has occurred. You can continue riding at any time without assistance from the drive, but you should have your eBike checked before completing any more journeys.

► **Only have repairs performed by a certified bicycle dealer.**

Code	Cause	Corrective measures
410	One or more buttons of the on-board computer are disabled.	Check whether any buttons are stuck, e.g. as a result of dirt finding its way in. Clean the buttons if need be.
414	Operating unit connection problem	Have the connections checked
418	One or more buttons on the operating unit are disabled.	Check whether any buttons are stuck, e.g. as a result of dirt finding its way in. Clean the buttons if need be.
419	Configuration error	Restart the system. If the problem persists, contact your Bosch eBike dealer.
422	Drive unit connection problem	Have the connections checked
423	eBike battery connection problem	Have the connections checked
424	Communication problem between components	Have the connections checked
426	Internal time-out error	Restart the system. If the problem persists, contact your Bosch eBike dealer. With this error, it is not possible to bring up the wheel circumference in the basic settings menu or to adjust it.
430	Internal battery of the on-board computer is flat	Charge the on-board computer (in the holder or via the USB port)

Code	Cause	Corrective measures
	(does not apply to BUI350)	
431	Software version error	Restart the system. If the problem persists, contact your Bosch eBike dealer.
440	Internal drive unit fault	Restart the system. If the problem persists, contact your Bosch eBike dealer.
450	Internal software error	Restart the system. If the problem persists, contact your Bosch eBike dealer.
460	Error at USB port	Remove the cable from the USB port of the on-board computer. If the problem persists, contact your Bosch eBike dealer.
490	Internal fault of the on-board computer	Have the on-board computer checked
500	Internal drive unit fault	Restart the system. If the problem persists, contact your Bosch eBike dealer.
502	Bike light fault	Check the light and the associated wiring. Restart the system. If the problem persists, contact your Bosch eBike dealer.
503	Speed sensor fault	Restart the system. If the problem persists, contact your Bosch eBike dealer.
504	Speed signal distortion detected.	Check that the spoke magnet is positioned correctly, and adjust it if necessary. Check that nothing has been tampered with (tuning). Drive assistance is reduced.
510	Internal sensor fault	Restart the system. If the problem persists, contact your Bosch eBike dealer.
511	Internal drive unit fault	Restart the system. If the problem persists, contact your Bosch eBike dealer.
530	Battery fault	Switch off the eBike, remove the eBike battery and reinsert the eBike battery.

Code	Cause	Corrective measures
		Restart the system. If the problem persists, contact your Bosch eBike dealer.
531	Configuration error	Restart the system. If the problem persists, contact your Bosch eBike dealer.
540	Temperature error	The eBike is outside of the permissible temperature range. Switch off the eBike system and allow the drive unit to either cool down or heat up to the permissible temperature range. Restart the system. If the problem persists, contact your Bosch eBike dealer.
550	An impermissible load has been detected.	Remove the load. Restart the system. If the problem persists, contact your Bosch eBike dealer.
580	Software version error	Restart the system. If the problem persists, contact your Bosch eBike dealer.
591	Authentication error	Switch off the eBike system. Remove the battery pack and reinsert it. Restart the system. If the problem persists, contact your Bosch eBike dealer.
592	Incompatible component	Use a compatible display. If the problem persists, contact your Bosch eBike dealer.
593	Configuration error	Restart the system. If the problem persists, contact your Bosch eBike dealer.
595, 596	Communication error	Check the wiring to the drive and restart the system. If the problem persists, contact your Bosch eBike dealer.
602	Internal battery fault	Restart the system. If the problem persists, contact your Bosch eBike dealer.
603	Internal battery fault	Restart the system. If the problem persists, contact your Bosch eBike dealer.
605	Battery temperature error	The battery is outside of the permissible temperature range. Switch off the eBike

Code	Cause	Corrective measures
		system and allow the battery to either cool down or heat up to the permissible temperature range. Restart the system. If the problem persists, contact your Bosch eBike dealer.
606	External battery fault	Check the wiring. Restart the system. If the problem persists, contact your Bosch eBike dealer.
610	Battery voltage error	Restart the system. If the problem persists, contact your Bosch eBike dealer.
620	Charger fault	Replace the charger. Contact your Bosch eBike dealer.
640	Internal battery fault	Restart the system. If the problem persists, contact your Bosch eBike dealer.
655	Multiple battery faults	Switch off the eBike system. Remove the battery pack and reinsert it. Restart the system. If the problem persists, contact your Bosch eBike dealer.
656	Software version error	Contact your Bosch eBike dealer so that they can perform a software update.
7xx	Error relating to third-party components	Observe the information in the operating instructions of the respective component manufacturer.
Display is blank	Internal fault of the on-board computer	Restart your eBike system by switching it off and back on.

Maintenance and cleaning

- ▶ **Deactivate the on-board computer if you are carrying out cleaning, maintenance or servicing work on the holder or the on-board computer.** Only then malfunctions/misuse can be avoided.

Do not clean any of the components with pressurized water.

Keep the screen of your on-board computer clean. Dirt can cause faulty brightness detection.

Clean your on-board computer using a soft cloth dampened only with water. Do not use cleaning products of any kind.

Have your eBike system checked by an expert at least once a year (including mechanical parts, up-to-dateness of system software).

The bike retailer can also schedule the service based on a mileage and/or a time period. In this case, the on-board computer displays a message telling you when the service date is due each time it is switched on.

Please have your eBike serviced and repaired by an authorized bicycle dealer.

- ▶ **Only have repairs performed by a certified bicycle dealer.**

Battery Recycling Program



The drive unit, on-board computer incl. operating unit, battery, speed sensor, accessories and packaging should be disposed of in an environmentally correct manner.

Do not dispose of eBikes and their components with household waste.



You may recycle your Bosch battery pack by calling 1.800.822.8837.

Robert Bosch GmbH

72757 Reutlingen

Germany

www.bosch-ebike.com

1 270 U20 Nen (2020.10) T / 71