

# Kiox

## Online Version (BUI330)



**en** Original operating instructions



# Table of Contents

Introduction .....	6
About Warnings .....	6
General Warnings.....	6
Using your Manual .....	7
Graphics .....	7
Safety instructions .....	8
Safety Warnings for charging the on-board computer battery .....	9
Safety Instructions in Conjunction with the Navigation System.....	10
Privacy notice.....	13
Congratulations .....	14
Product description and specifications .....	14
Intended use .....	14
Product features .....	16
Technical data .....	17
Fitting.....	18
Fitting and removing the on-board computer (see figure A) .....	18
Operation .....	20
Operating logic .....	20
Before initial commissioning .....	20
Switching the on-board computer on/off.....	20
Selecting system settings .....	21
Setting up the eBike system.....	22
Requirements .....	22
Switching the eBike system on/off .....	22
Energy supply of the on-board computer .....	22
Battery Charge Indicator .....	23
Storage mode/resetting the Kiox .....	24
Setting the assistance level.....	25
Switching the push assistance on/off .....	26
Switching bicycle lights on/off.....	26

Creating a user ID .....	26
Connecting the On-Board Computer with the Bosch eBike Connect App.....	27
<b>Activity tracking</b> .....	27
eShift (optional) .....	27
eSuspension (optional) .....	28
Lock (premium function) .....	28
Compatibility .....	28
Setting up the Lock function .....	29
How it works.....	29
Replacing eBike components and the Lock function .....	30
Software updates .....	31
Powering external devices from the USB port .....	31
Displays and settings of the on-board computer .....	32
Screen sequence .....	32
Start page .....	33
<b>Status screen</b> .....	34
<b>&lt;Settings&gt;</b> .....	35
<b>Quick Menu</b> .....	36
Troubleshooting.....	38
Displays and settings of the Bosch eBike Connect smartphone app.....	42
Activation of the Bosch eBike Connect Application.....	42
Registration via Smartphone.....	42
Main Menu of Bosch eBike Connect .....	44
<b>&lt;Activities&gt;</b> menu item .....	45
<b>&lt;Map&gt;</b> menu item.....	45
<b>&lt;My eBike&gt;</b> menu item .....	46
<b>&lt;Shop&gt;</b> menu item.....	46
Displays and Settings of the Online Portal .....	48
Online Registration.....	48
Online Portal Main Menu .....	49
<b>&lt;Route Planning&gt;</b> menu item.....	49

<b>&lt;Activities&gt;</b> menu item .....	52
<b>&lt;My eBike&gt;</b> menu item .....	52
<b>&lt;Help&gt;</b> menu item .....	52
Profile menu item  .....	52
Maintenance and servicing .....	54
Maintenance and cleaning .....	54
After-sales service and advice on using products .....	54
Transport.....	55
Battery Recycling Program .....	55

# Introduction

## About Warnings

This manual contains many **DANGER**, **WARNING**, and **CAUTION** indicators concerning the consequences of failure to use, assemble, maintain, store, inspect and dispose of a Bosch-equipped eBike in a safe manner.

- The combination of the safety alert symbol and the word **DANGER** indicates a hazardous situation that, if not avoided, will result in death or serious injury.
- The combination of the safety alert symbol and the word **WARNING** indicates a hazardous situation that, if not avoided, could result in death or serious injury.
- The combination of the safety alert symbol and the word **CAUTION** indicates a hazardous situation that, if not avoided, could result in minor or moderate injury.

## General Warnings



**Read all safety warnings and all instructions.** Failure to follow the warnings and instructions may result in death or serious injury.

### **Save all safety warnings and instructions for future reference.**

The term **battery pack** used in these operating instructions refers to all original Bosch eBike battery packs.

**This manual contains important safety, performance and service information.** Read it before you take the first ride on your new bicycle, and keep it for reference. The manual can also be found online at [www.bosch-ebike.com](http://www.bosch-ebike.com).

- ▶ **This manual is intended to be read together with the separate user manual provided with your bicycle.** Be sure to read all provided documents including labels on the product before your first ride.
- ▶ **Read ALL accompanying manuals before riding the bike for the first time.** Your Bosch Drive System comes with additional manuals and documents provided by the manufacturer of the bicycle and other components. Failure to read and understand safety information can result in death or serious injury.

- ▶ **Take responsibility for your own SAFETY.** If you have any questions or do not understand something, consult with your dealer or the bicycle or component manufacturer.
- ▶ **Some eBike accessories may present a choking hazard to small children.** Keep these accessories away from children.

**The Bosch Drive System adds weight to your bicycle which you may not be used to lift.** Avoid injury, use proper lifting techniques.

## Using your Manual

In addition to the functions outlined here, changes to software relating to troubleshooting and functional modifications may be introduced at any time.

### Graphics

The bicycle shown in this manual may differ slightly from your bicycle, but will be similar enough to help you understand our instructions.

RIGHT-HAND and LEFT-HAND sides are determined by facing in the direction the bicycle will travel when going forward. When you see a broken line (-----), the item referred to is hidden from view.

## Safety instructions



**Read all the safety information and instructions.** Failure to observe the safety information and follow instructions may result in electric shock, fire and/or serious injury.

### Save all safety warnings and instructions for future reference.

The term **battery pack** used in these operating instructions refers to all original Bosch eBike battery packs.

- ▶ **Do not allow yourself to be distracted by the display of the on-board computer.** If you do not concentrate exclusively on the traffic around you, you risk being involved in an accident. If you want to change any settings on the on-board computer other than the assistance level, always stop before entering the relevant data.
- ▶ **Set the display brightness such that you can adequately see important information like speed or warning symbols.** An incorrectly set display brightness can result in dangerous situations.
- ▶ **Do not open the on-board computer.** Opening the on-board computer can result in irreparable damage and void your warranty.
- ▶ **Do not use the on-board computer as a handle.** Lifting the eBike up by the on-board computer can cause irreparable damage to the on-board computer.
- ▶ **Do not stand your bicycle upside down on its saddle and handlebars if the on-board computer or its holder protrude from the handlebars.** This may irreparably damage the on-board computer or the holder. Also remove the on-board computer before placing the bicycle on a wall mount to ensure that the on-board computer does not fall off or become damaged.
- ▶ **Caution!** Using the on-board computer with *Bluetooth*<sup>®</sup> and/or WiFi can interfere with the operation of other devices and systems, including airplanes and medical devices (e.g. pacemakers, hearing aids). Similarly, the possibility that this may cause damage to humans and animals in the immediate vicinity cannot be completely excluded. Do not use the on-board computer with *Bluetooth*<sup>®</sup> in the vicinity of medical devices, service stations, chemical plants, blasting areas or other areas where there is a risk of explosion. Do not use the on-board computer with *Bluetooth*<sup>®</sup>



in airplanes. Avoid using the device in close proximity to your body over an extended period of time.

- ▶ The *Bluetooth*® word mark and logos are registered trademarks owned by Bluetooth SIG, Inc. and any use of such marks by Bosch eBike Systems is under licence.
- ▶ **The on-board computer is fitted with a radio interface. Local operating restrictions, e.g. in airplanes or hospitals, must be adhered to.**
- ▶ **Do not enter information or make selections while riding.** Interacting with the display unit while riding can lead to accidents causing serious injury or death. You must observe road and traffic conditions, and comply with traffic laws at all times.
- ▶ **Using your mobile device while operating an eBike may be distracting. Distracted driving is a serious safety concern and can lead to accidents causing serious injury or death. In order to prevent distracted driving, most devices come equipped with a “Do Not Disturb” mode. The “Do Not Disturb” mode should be used while operating an eBike.** Please consult your device-specific instructions for more information. You, as the eBike operator, are fully responsible for ensuring that you pay attention to road conditions and comply with traffic laws at all times.
- ▶ **Do not activate push assistance function while riding on the bike.** Only use push assistance function when pushing the eBike.

## Safety Warnings for charging the on-board computer battery

- ▶ **Only charge the on-board computer with USB power source (5 V, 1000 mA max) and USB cable rated at least 1000 mA.** Using USB power source or USB cable not appropriately rated for the application may result in fire, explosion or personal injury.
- ▶ **Charge the on-board computer in temperatures above +32 degrees F (0 degrees C) and below +104 degrees F (40 degrees C). Store on-board computer in locations where temperatures will not exceed 104 degrees F (40 degrees C).** This is important to prevent serious damage to the battery in the on-board computer.
- ▶ **Do not expose on-board computer to fire or excessive temperature.** Exposure to fire or temperature above 212 °F (100 °C) may cause explosion.

- ▶ **Do not recharge the on-board computer (via USB port) in damp or wet environment.** Water entering on-board computer may result in electric shock or fire.
- ▶ **Never submerge on-board computer in fluid of any kind or allow fluid to enter them.** Corrosive or conductive fluid (such as seawater or industrial chemical or bleach containing products, etc.) can cause short circuit which may result in fire, personal injury and property damage.
- ▶ **Battery leakage may occur under extreme usage or temperature conditions. Avoid contact with skin and eyes.** The battery liquid is caustic and could cause chemical burns to tissues. If liquid comes in contact with skin, wash quickly with soap and water. If the liquid contacts your eyes, immediately flush eyes with water for a minimum of 15 minutes and seek medical attention.
- ▶ **Place on-board computer on flat nonflammable surfaces and away from flammable materials when recharging on-board computer using external USB power source.** Carpeting and other heat insulating surfaces block proper air circulation which may cause overheating of the on-board computer. If smoke or melting of the on-board computer is observed, unplug the external USB power source immediately and do not use the on-board computer. Contact customer service immediately.
- ▶ **Before each use, check the on-board computer, cable and plug.** If damage is detected, do not use the on-board computer. Damaged on-board computer, charging cables and plugs increase the risk of a fire, explosion and personal injury.
- ▶ **Do not disassemble on-board computer.** No user serviceable part inside. Incorrect reassembly or damage may result in fire or explosion.

## Safety Instructions in Conjunction with the Navigation System

- ▶ **Do not plan any routes while riding. Make sure that you come to a complete stop and only input a new destination while at a standstill.** If you do not concentrate exclusively on the traffic around you, you risk being involved in an accident.
- ▶ **Discontinue following your route if the navigation system suggests a path for you to take that may be risky or dangerous for you according to your capabilities as a rider.** Allow the navigation system to select an alternative route for you instead.

- ▶ **Make sure to observe all traffic signs regardless of the route proposed by the navigation system.** The navigation system is unable to take roadworks or temporary diversions into account.
- ▶ **Do not use the navigation system in circumstances where special attention must be given to safety, or if it is unclear how to proceed (road closures, diversions, etc.).** Always carry additional map sources and means of communication.
- ▶ **The navigation system instructs you to perform an unsafe or illegal maneuver.** Cancel the navigation system and choose an alternative route.
- ▶ **The navigation system directs you into an unsafe area.** Cancel the navigation system and choose an alternative route.
- ▶ **The navigation system does not direct you to the nearest emergency facility when needed.** Make an emergency call and inquire as to the quickest available route.
- ▶ **The location of the bicycle is indicated incorrectly by the navigation system.** Use a secondary source of information to determine where you are located currently.
- ▶ **The volume of the navigation system prevents you from hearing surrounding traffic while riding.** Ensure that you are able to perceive sounds from traffic in the vicinity at all times, so that you can react to potential dangers appropriately.

**NOTICE:** This equipment complies with FCC radiation exposure limits set forth for an uncontrolled environment. This equipment should be installed and operated with minimum distance of 20 cm between the radiator and your body. This transmitter must not be co-located or operating in conjunction with any other antenna or transmitter:

1. This device must not cause harmful interference, and
2. this device must accept any interference that is received, including interference that may cause undesired operation.

**NOTICE:** Changes or modifications made to this equipment not expressly approved by the Robert Bosch GmbH may void the FCC authorization to operate this equipment.

**NOTE:** This equipment has been tested and found to comply with the limits for a Class B digital device, pursuant to Part 15 of the FCC Rules. These limits are designed to provide reasonable protection against harmful interfer-

ence in a residential installation. This equipment generates, uses and can radiate radio frequency energy and, if not installed and used in accordance with the instructions, may cause harmful interference to radio communications. However, there is no guarantee that interference will not occur in a particular installation. If this equipment does cause harmful interference to radio or television reception, which can be determined by turning the equipment off and on, the user is encouraged to try to correct the interference by one or more of the following measures:

- Reorient or relocate the receiving antenna.
- Increase the separation between the equipment and receiver.
- Connect the equipment into an outlet on a circuit different from that to which the receiver is connected.
- Consult the dealer or an experienced radio/TV technician for help.

**Radiofrequency radiation exposure Information:** The radiated output power of the device is far below the FCC radio frequency exposure limits. Nevertheless, the device shall be used in such a manner that the potential for human contact during normal operation is minimized.

**NOTICE:** This device complies with part 15 of the FCC Rules. Operation is subject to the following two conditions:

1. This device must not cause harmful interference, and
2. this device must accept any interference received, including interference that may cause undesired operation.

### **ISED Notice (Canada)**

This device contains licence-exempt transmitter(s)/receiver(s) that comply with Innovation, Science and Economic Development Canada's licence-exempt RSS(s). Operation is subject to the following two conditions:

1. this device may not cause interference, and
2. this device must accept any interference, including interference that may cause undesired operation of the device.

This equipment complies with Canada radiation exposure limits set forth for an uncontrolled environment. This equipment should be installed and operated with minimum distance of 20 cm between the radiator and your body. This transmitter must not be co-located or operating in conjunction with any other antenna or transmitter.

## Privacy notice

If the on-board computer is sent to Bosch Service because it requires servicing, the data stored on the on-board computer may be transmitted to Bosch.

## Congratulations

Congratulations on purchasing your eBike computer.

Kiox controls your eBike and reliably displays all your key ride data.

- eBike on-board computer with separate operating unit
- Can be connected via *Bluetooth*® to a heart rate monitor

### Updates

Kiox's range of functions is always being expanded. Keep your **Bosch eBike Connect** smartphone application up to date. Via this application, you can download new functions and transfer them to your Kiox.

In addition to the functions shown here, changes to software relating to troubleshooting and functional enhancements may be introduced at any time.

## Product description and specifications

### Intended use

The Kiox on-board computer is designed to control Bosch eBike systems and display riding data.

In order to use the Kiox on-board computer in full, a compatible smartphone with the eBike Connect app (available in the App Store or from Google Play) as well as registration in the eBike Connect portal ([www.ebike-connect.com](http://www.ebike-connect.com)) is required.

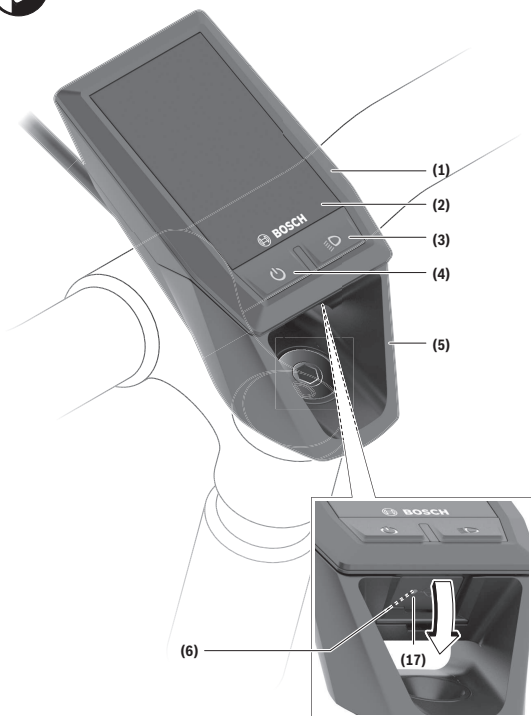

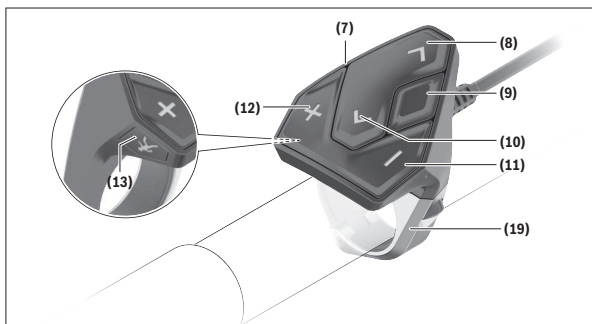

## Product features

- (1)** On-board computer
- (2)** Display
- (3)** Bike light button
- (4)** On/off button for on-board computer
- (5)** Holder for on-board computer
- (6)** USB port
- (7)** Operating unit
- (8)** Next/right page button >
- (9)** Select button
- (10)** Previous/left page button <
- (11)** Decrease assistance level button -/  
Scroll down button
- (12)** Increase assistance level button +/  
Scroll up button
- (13)** Push assistance button
- (17)** Protective cap for USB port<sup>A)</sup>
- (19)** Holder for operating unit

A) Available as spare part



## Technical data

On-board computer		Kiox
Product code		BUI330
Max. charging current of USB port <sup>A)</sup>	mA	1000
USB port charging voltage	V	5
USB charging cable <sup>B)</sup>		1 270 016 360
Operating temperature	°F	+23 to +104
Charging temperature	°F	+32 to +104
Storage temperature	°F	+50 to +104
Internal lithium-ion battery	V	3.7
	mAh	230
Protection rating <sup>C)</sup>		IP57
Weight, approx.	lbs	0.13
<i>Bluetooth® Low Energy</i>		
– Frequency	MHz	2400–2480
– Transmission power	mW	< 10

A) At an ambient temperature of <77 °F

B) Not included as part of standard delivery

C) When the USB cover is closed

## Fitting

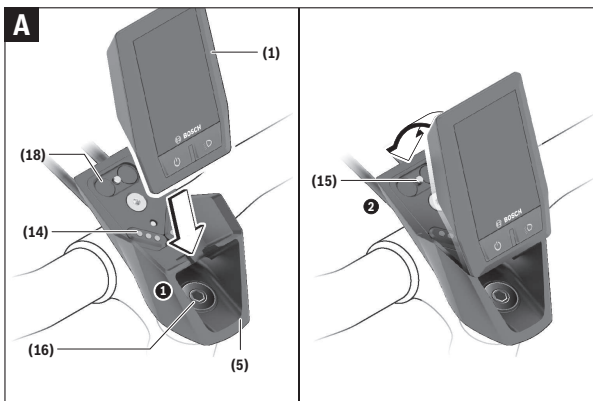

- (1) On-board computer
- (5) Holder for on-board computer
- (14) Drive unit contacts
- (15) Locking screw for on-board computer
- (16) Headset screw
- (18) Magnetic holder

### Fitting and removing the on-board computer (see figure A)

Fit the lower part of the Kiox into the holder (5) first and tilt it forward gently until you can feel that the on-board computer is firmly fixed in the magnetic holder.

To remove the on-board computer, hold it by the top end and pull it toward you until it disengages from the magnetic holder.

#### ► When you park up the eBike, remove the on-board computer.

The on-board computer can be secured in place to prevent it from being removed from the holder. To do this, loosen the headset screw (16) until the

Kiox holder can be swiveled sideways. Put the on-board computer in the holder. Screw the locking screw (M3, 6 mm long) from below into the thread provided in the on-board computer (using a longer screw may damage the on-board computer). Swivel the holder back into place and tighten the headset screw in accordance with the manufacturer's specifications.

# Operation

## Operating logic

You can use the **< (10)** and **> (8)** buttons to switch between the different riding value information pages (even while riding). This way, you can keep both hands on the handlebars while cycling.

You can use the **+ (12)** and **- (11)** buttons to increase or decrease the assistance level.

The **<Settings>** that can be accessed via the **Status screen** cannot be changed while riding.

You can use the select button **(9)** to perform the following functions:

- You can access the quick menu while riding.
- You can access the settings menu from the **Status screen** while stationary.
- You can confirm values and acknowledge informative hints.
- You can exit a dialog.

If the on-board computer is removed from its holder and not switched off, it will display information regarding the last journey, as well as status information, on a loop.

If no button is pressed after the on-board computer is removed from the holder, it will switch itself off after one minute.

## Before initial commissioning

The **Kiox** is supplied with a partially charged battery. Before using it for the first time, this battery must be charged for at least one hour via the USB port (see "Energy supply of the on-board computer", page English – 22) or via the eBike system.

The control unit should be attached such that the buttons are almost perpendicular to the handlebars.

When turning on the on-board computer for the first time, the language selection is displayed and then you can use the menu item **<Intro to Kiox>** to find out more about the main functions and displays. You can access this menu item again at a later time via **<Settings>** → **<Information>**.

## Switching the on-board computer on/off

To **switch on** and **switch off** the on-board computer, briefly press the on/off button **(4)**.

## Selecting system settings

Fit the on-board computer in the holder and proceed as follows while the bicycle is stationary:

Go to the status page (use the button **< (10)** on the operating unit to get to the first display) and press the select button **(9)** to call up the **<Settings>**. You can use the **- (11)** and **+ (12)** buttons to select the setting you want. You can open the settings, as well as any additional submenus, using the select button **(9)**. You can use the button **< (10)** to go back to the previous menu from any settings menu.

The following settings can be changed in the **<Sys settings>**:

- **<Brightness>**  
The brightness can be adjusted in steps of 10 % from 0–100 %. The values can be adjusted with the **</>** buttons and selected with the **+/-** buttons. When the **<Automatic>** option is selected, the brightness automatically adjusts to the ambient light.
- **<Time>**  
The values can be adjusted with the **</>** buttons and selected with the **+/-** buttons.
- **<Date [DD.Mon.YYYY]>**  
The current date can be set here.
- **<Time zone>**  
The correct time zone can be selected here.
- **<24h form (24h time format)>**  
This time format can be switched on or off.
- **<Brgh backg. (Bright background)>**  
The bright background can be switched on or off.
- **<Imp. units (Imperial units)>**  
If this option is switched on, imperial measurements are used (e.g. miles instead of kilometers).
- **<Language>**  
The required language for the interface can be selected here from nine options.
- **<Factory reset>**  
This menu item can be used to reset the on-board computer to factory settings.

## Setting up the eBike system

### Requirements

The eBike system can only be activated when the following requirements are met:

- A sufficiently charged eBike battery is inserted (see battery operating instructions).
- The on-board computer is properly inserted in the holder.

### Switching the eBike system on/off

The following options are available for **switching on** the eBike system:

- Once the on-board computer and the eBike battery are fitted, briefly press the on/off button **(4)** on the on-board computer.
- With the on-board computer inserted, press the on/off button on the eBike battery (bicycle manufacturer-specific solutions are possible when there is no access to the battery on/off button; see the operating instructions from the bicycle manufacturer).

The drive is activated as soon as you start pedaling (except for in the push assistance function or with the assistance level **OFF**). The motor output depends on which assistance level is set on the on-board computer.

As soon as you stop pedaling when in normal operation, or as soon as you have reached a speed of **20/28 mph**, the eBike drive unit switches off the assistance. The drive is automatically re-activated as soon you start pedaling again and the speed is below **20/28 mph**.

The following options are available for **switching off** the eBike system:

- Briefly press the on/off button **(4)** of the on-board computer.
- Switch off the eBike battery using its on/off button (some bicycle manufacturer-specific solutions prevent access to the battery on/off button; see the bicycle manufacturer operating instructions).
- Remove the on-board computer from its holder.

If no power is drawn from the eBike drive for about 10 minutes (e.g. because the eBike is not moving) and no button is pressed on the on-board computer or the operating unit of the eBike, the eBike system, and therefore also the battery, will switch off automatically to save energy.

### Energy supply of the on-board computer

If the on-board computer is in the holder **(5)**, a sufficiently charged eBike battery is inserted into the eBike and the eBike system is switched on, then

the on-board computer battery is powered and charged by the eBike battery.

If the on-board computer is removed from the holder **(5)**, the power is supplied by the on-board computer battery. If the on-board computer battery's charge is running low, a warning message appears on the display.

To charge the on-board computer battery, put the on-board computer back in the holder **(5)**. Note that if you are not charging the eBike battery, the eBike system will automatically switch off after 10 minutes if it is not activated. If this happens, the on-board computer battery will also stop charging.

You can also charge the on-board computer via the USB port **(6)**. To do this, open the protective cap **(17)**. Use a Micro USB cable to connect the USB port on the on-board computer to a commercially available USB charger (not included with the product as standard) or to the USB port of a computer (max. **5 V** charging voltage; max. **1000 mA** charging current).

If the on-board computer is removed from the holder **(5)**, all values of the functions are saved and are still displayed.

Following use, the USB port must be carefully resealed with the protective cap **(17)**.

If the Kiox battery is not recharged, the date and time will be retained for up to six months. When the on-board computer is switched on again, the date and time will be reset if a *Bluetooth*<sup>®</sup> connection to the app has been established and the smartphone has successfully identified the current location via GPS.

**Note:** The Kiox **only** charges while it is switched on.

**Note:** If the Kiox is switched off during charging via a USB cable, the Kiox can only be switched on again once the USB cable has been disconnected.

**Note:** To maximize the lifespan of the on-board computer battery, it should be recharged for one hour every three months.

## Battery Charge Indicator

The battery charge indicator of the eBike battery **d** (see "Start page", page English – 33) can be read on the status page and in the status bar. The eBike battery's state of charge is also indicated by the LEDs on the eBike battery itself.

Color of the indicator	Meaning
White	The eBike battery is over 30 % charged.
Yellow	The eBike battery is charged between 15 % and 30 %.
Red	The eBike battery is charged between 0 % and 15 %.
Red + !	The capacity for assisting the drive has been used up, and assistance is switched off. The remaining capacity will be provided for the bike lights and the on-board computer.

If the eBike battery is being charged on the bike, a corresponding notification will be displayed.

If the on-board computer is removed from the holder **(5)**, the state of charge that was last displayed for the battery is saved.

## Storage mode/resetting the Kiox

The on-board computer has an energy-saving storage mode, which minimizes the rate at which the internal battery discharges. Setting to this mode erases the date and time.

This mode can only be activated by pressing and holding the on/off button **(4)** of the on-board computer (for at least eight seconds).

If the on-board computer does not start when the on/off button **(4)** is pressed briefly, the on-board computer is in storage mode.

You can deactivate storage mode by pressing the on/off button **(4)** for at least two seconds.

The on-board computer detects whether it is in fully working order. If you press and hold the on/off button **(4)** for at least eight seconds while the on-board computer is in fully working order, it will go into storage mode. If, contrary to expectations, the Kiox is not in working order and cannot be operated, pressing and holding the on/off button **(4)** (for at least eight seconds) will reset it. After being reset, the on-board computer will restart automatically after approx. five seconds. If the Kiox does not restart, press the on/off button **(4)** for two seconds.



To reset the Kiox to its factory settings, select **<Settings>** → **<Sys settings>** → **<Factory reset>**. All user data will be lost.

## Setting the assistance level

On the operating unit **(7)**, you can set the level of assistance you want the eBike drive to provide you with while pedalling. The assistance level can be changed at any time, even while cycling.

**Note:** In some models, the assistance level may be preset and cannot be changed. There may also be fewer assistance levels available than stated here.

The following assistance levels are available as a maximum:

- **OFF:** Motor assistance is switched off. The eBike can just be moved by pedaling, as with a normal bicycle. The push assistance cannot be activated at this assistance level.
- **ECO:** Effective assistance with maximum efficiency, for maximum range
- **TOUR:** Steady assistance, long range for touring
- **SPORT/eMTB:**
  - SPORT:** Powerful assistance, for mountain biking and for cycling in urban traffic
  - eMTB:** Optimum assistance whatever the terrain, rapid acceleration when starting from a standstill, improved dynamics, top performance (**eMTB** is only available in combination with drive units BDU250P CX, BDU365, BDU450 CX and BDU480 CX. This also requires a software update.)
- **TURBO:** Maximum assistance even at high pedaling speeds, for biking sports

To **increase** the assistance level, press the **+ (12)** button on the operating unit repeatedly until the desired assistance level appears on the display. To **decrease** the assistance level, press the **– (11)** button.

The requested motor output appears on the display **h** (see "Start page", page English – 33). The maximum motor output depends on the selected assistance level.

If the on-board computer is removed from the holder **(5)**, the assistance level that was last displayed is saved.

## Switching the push assistance on/off

The push assistance aids you when pushing your eBike. The speed of this function depends on the selected gear and can reach a maximum of **3.7 mph**. The lower the selected gear, the lower the speed of the push assistance function (at full power).

► **The push assistance function must only be used when pushing the eBike.** There is a risk of injury if the wheels of the eBike are not in contact with the ground while using the push assistance.

To **activate** the push assistance, briefly press the **WALK** button on your on-board computer. After activation, press the **+** button within 3 s and keep it pressed. The eBike drive is switched on.

**Note:** The push assistance cannot be activated at assistance level **OFF**.

The push assistance is **switched off** as soon as one of the following occurs:

- You release the **+** button;
- the wheels of the eBike are locked (e.g. by applying the brakes or hitting an obstacle);
- the speed exceeds **3.7 mph**.

The push assistance function is subject to local regulations; the way it works may therefore differ from the description above. It can also be deactivated.

## Switching bicycle lights on/off

On the model in which the lighting is powered by the eBike system, the front and rear lights can be switched on and off at the same time via the on-board computer using the bike light button **(3)**.

Before starting each journey, check that your bike lights are working correctly.

If the lighting is switched on, the bike light indicator **c** (see "Start page", page English – 33) lights up in the status bar of the display.

Switching the bike lights on and off has no effect on the backlighting of the display.

## Creating a user ID

In order to be able to use all the functions of the on-board computer, you must register online.

With a user ID, you can analyze your ride data, plan offline routes and transfer these routes to the on-board computer.

You can set up a user ID via your **Bosch eBike Connect** smartphone app or simply at [www.eBike-Connect.com](http://www.eBike-Connect.com). Enter the details required for registration. The **Bosch eBike Connect** smartphone app is available to download free of charge from the App Store (for Apple iPhones) or from the Google Play store (for Android devices).

## Connecting the On-Board Computer with the Bosch eBike Connect App

Follow these steps to establish a connection to your smartphone:

- Load the app.
- Select the tab **<My eBike>**.
- Select **<Add new eBike device>**.
- Add **Kiox**.

The app will then display an instruction to press and hold the bike lighting button **(3)** on the on-board computer for 5 seconds.

Press and hold the button **(3)** for at least 5 seconds. The on-board computer automatically activates the *Bluetooth® Low Energy* connection and switches to pairing mode.

Follow the instructions on the screen. Once pairing is complete, the user data is synchronized.

**Note:** The *Bluetooth®* connection does not need to be activated manually.

## Activity tracking

In order to record activities, you must be registered with and logged into the eBike Connect portal or the eBike Connect app.

To record activities, you must consent to the storage of your location data either in the portal or in the app. Without this, your activities will not be shown in the portal or the app. The position is only recorded if you as a user are logged into the on-board computer.

## eShift (optional)

eShift is the integration of electronic gear shifting systems into the eBike system. The eShift components are electrically connected to the drive unit by the manufacturer. The separate operating instructions describe how to operate the electronic gear-shifting systems.

## eSuspension (optional)

eSuspension is the integration of electronic shock absorption and suspension elements into the eBike system. You can use the **Quick Menu** to select predefined settings for the eSuspension system, provided that this type of system is fitted on your eBike.

When switching on the system or inserting the Kiox into the holder, you will briefly be shown which eSuspension mode is activated. The system is always started in the mode that was last active.

If you remove the Kiox, when the battery is empty or when you are traveling on reserve power for the lights, the suspension will be set to the soft mode. For details of these settings, please refer to the operating instructions provided by the eSuspension manufacturer.

eSuspension is only available in combination with the Kiox on-board computer and can only be used with the BDU450 CX, BDU480 CX and BDU490P drive units.

## Lock (premium function)

The Lock function is available to purchase from the **<Shop>** in the eBike Connect app. Once the Lock function has been set up and the Lock has been activated by removing the on-board computer, the eBike drive unit assistance is deactivated. It can only be activated using the on-board computer associated with the eBike.

The Lock function is linked to your **user account**, which you can use to log into the **eBike Connect app**. The account allows you to use the Lock function with an on-board computer, which in turn can be used to activate the function on up to four eBikes.

Note that 2 hours must have passed in between any 2 activations of the Lock function.

**Warning!** If you attempt to change a setting in the app, the on-board computer or the portal that could have negative consequences in combination with the Lock function (e.g. deleting your eBike or user account), you will be shown warning messages beforehand. **Please read through these thoroughly and adhere to the warnings that are issued (e.g. before deleting your eBike or user account).**

## Compatibility

The Lock function is compatible with these Bosch eBike product lines:

Drive unit	Product line
BDU3xx	Active Line, Active Line Plus, Performance Line
BDU4xx	Performance Line Speed, Cargo Line, Cargo Line Speed, Performance Line CX

### Setting up the Lock function

In order to be able to set up the Lock function, the following conditions must be fulfilled:

- You have purchased the Lock function.
- The on-board computer is situated in the holder on the eBike.
- The on-board computer is connected to the smartphone via *Bluetooth*<sup>®</sup>.
- The smartphone is connected to the Internet.

Go to the **<My eBike>** menu item in your eBike Connect app and set up the Lock function for your eBike by sliding the control **<Lock feature>** to the right.

From now on, you can deactivate the assistance from your drive unit by removing the on-board computer. The drive unit assistance can only be reactivated with the on-board computer that was used in the setup.

Even with the Lock function activated, you can continue to use your eBike without assistance from the drive unit.

### How it works

In combination with the Lock function, the on-board computer functions similarly to a key for the drive unit. The Lock function is activated and deactivated by respectively removing or inserting the on-board computer. The status of the Lock function is indicated by a padlock symbol that appears on the display of the on-board computer for approx. three seconds following its insertion.

Remove the on-board computer from its holder whenever you are away from the eBike so that the Lock function can fulfill its intended purpose.

If the on-board computer used in setting up the Lock function is not inserted on your eBike, the drive unit will not provide any assistance. However, you can still continue to use your eBike without assistance.

**Note:** The Lock function alone does not provide adequate theft protection; it is simply a supplement to a mechanical lock. The Lock function does not pro-

vide any form of mechanical lock for the eBike. Only the assistance from the drive unit is deactivated.

If you wish to give other users temporary or permanent access to your eBike, you will need to deactivate the Lock function in the eBike Connect app.

If you remove the on-board computer, the drive unit will emit a "Lock" sound (i.e. an audio signal that is played **once**) to indicate that the assistance from the drive unit is switched off.

**Note:** The audio signal will only be played if the system is switched on.

If you reinsert the on-board computer, the drive unit will emit two "Unlock" sounds (i.e. an audio signal that is played **twice**) to indicate that the assistance from the drive unit is enabled again.

The "Lock" sound will help you determine whether or not the Lock function on your eBike is active. The audio signal is activated by default, but it can be deactivated under **<My eBike>** by selecting the lock symbol below your eBike.

In the eBike Connect app, the Lock function under **<My eBike>** is indicated with a lock symbol next to the bikes.

**Attention:** The lock symbol is only shown for eBikes that are suitable for the Lock function. Note the information in the section on compatibility.

Please contact your bike dealer if any of the following occurs:

- The Lock function can no longer be set up or switched off
- Your eBike Connect account has been deleted or deactivated, yet the Lock function has been set up and remains active.

## Replacing eBike components and the Lock function

### Replacing the smartphone

1. Install the eBike Connect app on the new smartphone.
2. Log in with **the same** account that was used to activate the Lock function.
3. Connect your smartphone with the on-board computer while the on-board computer is attached.
4. The Lock function is displayed as set up and active in the eBike Connect app.

### Replacing the on-board computer

1. Connect your smartphone with the on-board computer while the on-board computer is attached.

2. The Lock function is displayed as set up and active in the eBike Connect app.

### Replacing the Drive Unit

1. The Lock function is displayed as set up and deactivated in the eBike Connect app.
2. Activate the Lock function by sliding the **Lock function** control to the right.

## Software updates

Software updates are transferred from the app to the on-board computer in the background as soon as the app is connected with the on-board computer. If an update has been fully transferred, this is shown **three times** upon restarting the on-board computer.

Alternatively, you can check for the presence of any updates via **<Sys settings>**.

## Powering external devices from the USB port

The USB port can be used to operate or charge most devices that can be powered via USB (e.g. various mobile phones).

Charging requires the on-board computer to be mounted and a sufficiently charged battery to be inserted in the eBike.

Open the protective cap **(17)** for the USB port on the on-board computer. Use a Micro-A – Micro-B USB charging cable (available from your Bosch eBike dealer) to connect the USB port on the external device to the USB port **(6)** on the on-board computer.

Once the electrical load has been disconnected, the USB port must be carefully resealed with the protective cap **(17)**.

**A USB connection is not a watertight plug connection. When cycling in wet conditions, ensure no external devices are connected and that the USB port is fully covered by the protective cap (17).**

**Attention:** Any electrical devices connected can reduce the range of the eBike.

## Displays and settings of the on-board computer

**Note:** All interface displays and texts on the following pages correspond to the release status of the software. The interface displays and texts may change slightly following a software update.

### Screen sequence

Provided the on-board computer is fitted to the holder, you can view the following displays one after the other:

1. Start page
2. Time and range
3. Distance and journey time
4. Power and cadence
5. Average and maximum speed
6. Distance, range, power and heart rate
7. Heart rate
8. Calories burnt and total distance
9. Status page



## Start page

When you insert the on-board computer into the holder while it is switched on, it will display the start page.

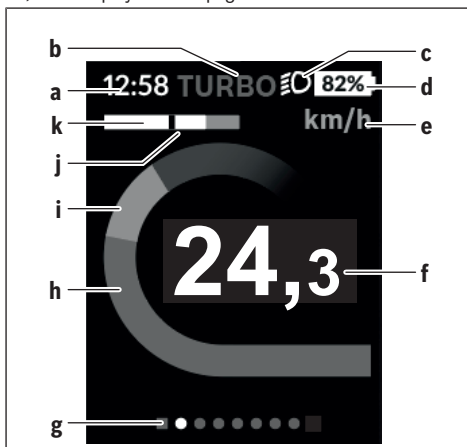

- a** Time/speed indicator
- b** Assistance level indicator
- c** Lighting indicator
- d** Battery charge indicator of the eBike battery
- e** Unit of speed indicator<sup>A)</sup>
- f** Speed
- g** Navigation bar
- h** Motor output
- i** Your performance
- j** Average speed
- k** Performance evaluation

A) Can be changed via the **<Settings>** status page.

The **a ... d** indicators form the status bar and are shown on every page. If the speed is already being displayed on the screen itself, the **a** indicator will change to the current time in hours and minutes. The status bar displays:

- **Speed/time:** The current speed in km/h or mph or the current time
- **Assistance level:** Indicates the current level of assistance using a color code
- **Light:** A symbol that indicates whether the light is on
- **eBike battery state of charge:** Indicates the current state of charge as a percentage

The performance evaluation **k** graphically displays your current speed (white bar) in comparison to your average speed **j**. The graphic shows you whether your current speed is faster or slower than your average speed (left of the black line = lower than average value; right of the black line = higher than average value).

The navigation bar **g** indicates which page you are on. Your current page is highlighted. You can use the **< (10)** and **> (8)** buttons to move to additional pages.

From the initial start page, you can access the status page via the **< (10)** button.

## Status screen

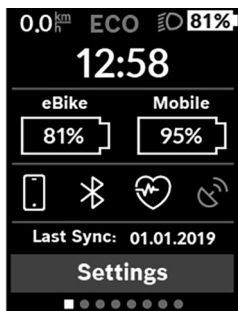

As well as the status bar, the status page also shows you the current time and the state of charge of all your eBike's batteries, as well as the state of charge of your smartphone battery if the smartphone is connected via *Bluetooth®*.

It may also display symbols to indicate an activated *Bluetooth®* function or a device connected via *Bluetooth®* (e.g. a heart-rate monitor). You will also be shown the date of the most recent synchronization between the smartphone and Kiox.

You can access the **<Settings>** from the bottom section.

## <Settings>

You can access the settings menu via the status screen. The **<Settings>** cannot be accessed or changed while riding.

You can use the **- (11)** and **+ (12)** buttons to select the setting you want. You can open the settings, as well as any additional submenus, using the select button **(9)**. You can use the button **< (10)** to go back to the previous menu from any settings menu.

You can find the following superordinate sections on the first navigation level:

- **<Registration>** You can register here, if you have not yet done so via the app or the portal. This menu item is displayed only if you have not yet completed registration.
- **<My eBike>** – Settings for your eBike
 

You can reset the counters (such as the number of kilometers traveled that day or average values) to "0" either automatically or manually, and you can reset the range. You can change the wheel circumference value that was preset by the manufacturer by  $\pm 5\%$ . If your eBike features **eShift**, you can also configure your eShift system here. The bike retailer can schedule the service based on a mileage and/or a time period. The bike component page displays the serial number and hardware and software versions for each component, in addition to other key data that is relevant for the components.

  - **<Reset>** Indicates when the last reset took place. The trip distance and average values can be reset.
  - **<Res. tr. dat. Aut. (Reset trip data automatically)>** Select from **<Off>**, **<Once a day>** or **<Aft inact 4h (After 4 hours of inactivity)>**
  - **<Reset range (Reset range calculation now)>** The value can be reset to the standard setting here.
  - **<eShift>** The cadence and starting gear can be set here.
  - **<Wheel circum.Min. xxx max. yyy (Wheel circumference Min. xxx max yyy)>** The value of the wheel circumference can be adjusted or reset to the standard setting here.
  - **<Next Service: [DD. Mon. YYYY] or at [xxxxx] [km]>** only appears if a service date has been entered by the manufacturer or dealer.
  - **<eBike comps (My eBike components)>**

- **<Screens>** Here you can set the content and order of the screens, and reset these to factory settings if required.
- **<Bluetooth>** – Switching the *Bluetooth*® function on or off:  
Connected devices are displayed.  
Go to **<Settings>** → **<Bluetooth>** to add a new device or remove a device that is no longer required.  
Recommended heart rate monitors:
  - Polar H7
  - Polar H10 Heart Rate Sensor
  - Runtastic Heart Rate Combo Monitor
  - Wahoo TICKR Heart Rate Monitor
  - BerryKing Heartbeat chest strap
  - BerryKing Sportbeat armband  
May be compatible with other devices.
- **<Sys settings>**  
You can display the speed and distance in kilometers or miles, display the clock in 12- or 24-hour format, adjust the time, date and time zone and select your preferred language. You can reset Kiox to its factory settings, run a software update (if available) and choose between a black or white design. Under the **<My profile>** item, you can see which account your Kiox is currently connected with. To regulate the brightness of the display, you can activate or deactivate the light sensor.
- **<Information>**
  - **<Registration>**
  - **<FAQs>**
  - **<Intro to Kiox>**
  - **<Certifications>**
  - **<License info>**
  - **<Contact us>**

## Quick Menu

Selected settings are displayed on the **Quick Menu**. These settings can be changed even while riding.

You can access the **Quick Menu** via the select button **(9)**. It cannot be accessed from the **Status screen**.

The following settings can be changed via the **Quick Menu**:

- **<Reset trip data?>**  
All data on the journey so far is reset to zero.
- **<eShift>**  
You can set the cadence here.
- **<eSuspension>**  
This is where you can set a manufacturer-defined shock absorption or suspension mode.

## Troubleshooting

The components of the eBike system are continuously monitored automatically. If a fault is detected, the corresponding fault code will appear on the on-board computer.

The drive may also be switched off automatically depending on what type of fault has occurred. You can continue riding at any time without assistance from the drive, but you should have your eBike checked before completing any more journeys.

► **Only have repairs performed by a certified bicycle dealer.**

Code	Cause	Corrective measures
410	One or more buttons of the on-board computer are disabled.	Check whether any buttons are stuck, e.g. as a result of dirt finding its way in. Clean the buttons if need be.
414	Operating unit connection problem	Have the connections checked
418	One or more buttons on the operating unit are disabled.	Check whether any buttons are stuck, e.g. as a result of dirt finding its way in. Clean the buttons if need be.
419	Configuration error	Restart the system. If the problem persists, contact your Bosch eBike dealer.
422	Drive unit connection problem	Have the connections checked
423	eBike battery connection problem	Have the connections checked
424	Communication problem between components	Have the connections checked
426	Internal time-out error	Restart the system. If the problem persists, contact your Bosch eBike dealer. With this error, it is not possible to bring up the wheel circumference in the basic settings menu or to adjust it.
430	Internal battery of the on-board computer is flat	Charge the on-board computer (in the holder or via the USB port)

Code	Cause	Corrective measures
	(does not apply to BUI350)	
431	Software version error	Restart the system. If the problem persists, contact your Bosch eBike dealer.
440	Internal drive unit fault	Restart the system. If the problem persists, contact your Bosch eBike dealer.
450	Internal software error	Restart the system. If the problem persists, contact your Bosch eBike dealer.
460	Error at USB port	Remove the cable from the USB port of the on-board computer. If the problem persists, contact your Bosch eBike dealer.
490	Internal fault of the on-board computer	Have the on-board computer checked
500	Internal drive unit fault	Restart the system. If the problem persists, contact your Bosch eBike dealer.
502	Bike light fault	Check the light and the associated wiring. Restart the system. If the problem persists, contact your Bosch eBike dealer.
503	Speed sensor fault	Restart the system. If the problem persists, contact your Bosch eBike dealer.
504	Speed signal distortion detected.	Check that the spoke magnet is positioned correctly, and adjust it if necessary. Check that nothing has been tampered with (tuning). Drive assistance is reduced.
510	Internal sensor fault	Restart the system. If the problem persists, contact your Bosch eBike dealer.
511	Internal drive unit fault	Restart the system. If the problem persists, contact your Bosch eBike dealer.
530	Battery fault	Switch off the eBike, remove the eBike battery and reinsert the eBike battery.

Code	Cause	Corrective measures
		Restart the system. If the problem persists, contact your Bosch eBike dealer.
531	Configuration error	Restart the system. If the problem persists, contact your Bosch eBike dealer.
540	Temperature error	The eBike is outside of the permissible temperature range. Switch off the eBike system and allow the drive unit to either cool down or heat up to the permissible temperature range. Restart the system. If the problem persists, contact your Bosch eBike dealer.
550	An impermissible load has been detected.	Remove the load. Restart the system. If the problem persists, contact your Bosch eBike dealer.
580	Software version error	Restart the system. If the problem persists, contact your Bosch eBike dealer.
591	Authentication error	Switch off the eBike system. Remove the battery pack and reinsert it. Restart the system. If the problem persists, contact your Bosch eBike dealer.
592	Incompatible component	Use a compatible display. If the problem persists, contact your Bosch eBike dealer.
593	Configuration error	Restart the system. If the problem persists, contact your Bosch eBike dealer.
595, 596	Communication error	Check the wiring to the drive and restart the system. If the problem persists, contact your Bosch eBike dealer.
602	Internal battery fault	Restart the system. If the problem persists, contact your Bosch eBike dealer.
603	Internal battery fault	Restart the system. If the problem persists, contact your Bosch eBike dealer.
605	Battery temperature error	The battery is outside of the permissible temperature range. Switch off the eBike



Code	Cause	Corrective measures
		system and allow the battery to either cool down or heat up to the permissible temperature range. Restart the system. If the problem persists, contact your Bosch eBike dealer.
606	External battery fault	Check the wiring. Restart the system. If the problem persists, contact your Bosch eBike dealer.
610	Battery voltage error	Restart the system. If the problem persists, contact your Bosch eBike dealer.
620	Charger fault	Replace the charger. Contact your Bosch eBike dealer.
640	Internal battery fault	Restart the system. If the problem persists, contact your Bosch eBike dealer.
655	Multiple battery faults	Switch off the eBike system. Remove the battery pack and reinsert it. Restart the system. If the problem persists, contact your Bosch eBike dealer.
656	Software version error	Contact your Bosch eBike dealer so that they can perform a software update.
7xx	Error relating to third-party components	Observe the information in the operating instructions of the respective component manufacturer.
Display is blank	Internal fault of the on-board computer	Restart your eBike system by switching it off and back on.

## Displays and settings of the Bosch eBike Connect smartphone app

A smartphone is not one of the items included. An Internet connection is required to register with a smartphone, which, depending on how the contract has been drafted, may incur costs from your telephone provider. An Internet connection is also required to synchronize data between the smartphone and online portal.

**Note:** All interface displays and texts on the following pages correspond to the release status of the software. As the software may be updated over the course of the year, it is possible that the interface displays and/or texts may change.

The following description of the eBike Connect app applies to the Kiox (BUI330) and Nyon (BUI27x and BUI350) on-board computers.

### Activation of the Bosch eBike Connect Application

To be able to use all eBike Connect functions, a smartphone with the **Bosch eBike Connect** application is required.

Proceed as follows to activate:

1. Open Google Play Store (Android) or the App Store (iOS) on your smartphone.
2. Search for **Bosch eBike Connect**.
3. Install and open the **Bosch eBike Connect** application.
4. Register as described in the next section.











Should you have already registered via the online portal ([www.ebike-connect.com](http://www.ebike-connect.com)), you can also log in directly with your login details.

### Registration via Smartphone

- Start the **Bosch eBike Connect** application.
- Select **<Sign up>**.
- Read and accept the General Terms and Conditions and the privacy statement.
- After confirmation, you will receive an e-mail to your specified e-mail address with the contractual provisions.
- Activate your user account by clicking the button in your e-mail.

If the **Bosch eBike Connect** application is active and there is a *Bluetooth*<sup>®</sup> connection to your on-board computer, data is automatically synchronized between the on-board computer and smartphone.

## Main Menu of Bosch eBike Connect

Symbol	Menu item	Function
	<b>&lt;Feed&gt;</b>	Under this menu item, you will find an overview of the kilometers ridden in the past month, a display of the last activity that has not yet been completed and current messages.
	<b>&lt;Activities&gt;</b>	The distances you have ridden are displayed under this menu item.
	<b>&lt;Map&gt;</b>	You can plan routes via this menu item. Saved routes are automatically synchronized between the app and the on-board computer (not for BUI330).
	<b>&lt;My eBike&gt;</b>	Via this menu item, you can select your on-board computer and adjust your eBike settings.
	<b>&lt;More&gt;</b>	This button can show you further menu items.
	<b>&lt;Shop&gt;</b>	Via this menu item, you can purchase premium functions that are compatible with your product.
	<b>&lt;Settings&gt;</b>	Via this menu item, you can view and edit your personal data and your data protection and app settings, as well as download maps for offline use of the app.
	<b>&lt;Help&gt;</b>	You can find answers to <b>&lt;FAQs&gt;</b> under this menu item.
	<b>&lt;Imprint&gt;</b>	Under this menu item, you can find the manufacturer contact details.
	<b>&lt;About&gt;</b>	Under this menu item, you can find content including the application version, the Terms of Use, the description of the service and the data protection notice.

### <Activities> menu item

Under the <Activities> menu item, you can see the ridden routes that were not previously planned in the online portal (e.g. via Komoot).

After synchronization, your journeys are displayed on the map. The synchronization status is displayed on the on-board computer.

When you select a journey, the route traveled is displayed to you on a map, in addition to the distance, journey duration and average speed. In addition, three further pages are available with driving statistics data.

### <Map> menu item

The map displayed here is intended for viewing and destination input, but route tracing – as with Google Navigation, for instance – is not possible.

When you have selected this menu item, your current location will be shown using the GPS function of the smartphone.

You can select saved locations via the search function. You can also enter a destination by clicking on the map.

Once you have entered the destination, you will be offered three different routes (<Fast>, <Scenic> and <Mountain bike>) displaying the elevation profile.

- The <Fast> route shows you the fastest connection from your location to your selected destination while avoiding steeper slopes.
- The <Scenic> route shows you the most scenic connection from your location to your selected destination and avoids main roads.
- The <Mountain bike> route guides you over mostly unpaved trails and offers the best route for a mountain bike (not for eBikes up to 45 km/h).

**Note:** The different <Fast>, <Scenic> and <Mountain bike> routes may be identical on short routes.

If you are using **Nyon**, the planned route is automatically transmitted to **Nyon** as soon as there is a connection between the app and Nyon.

If you are using **Kiox**, then you transmit the planned route by selecting the button to start the route and confirm with OK once you have read the safety instructions.

In addition to route planning, you can find your previously saved destinations and routes in the search history. Based on your current location, you can also receive directions to take you home or to work.

### <My eBike> menu item

Upon initial installation of the app, a connection between the app and the on-board computer is established via this menu item.

To achieve this, select **<Add new eBike device>** and follow the instructions.

Once successfully linked, the currently connected on-board computer and its associated eBike components will be displayed.

The eBikes that were connected with Kiox or Nyon will be displayed.

If the on-board computer has already been fitted on at least two different eBikes, these will be displayed here and can be selected. Otherwise, no selection is possible. For each eBike, the name can be changed or the eBike can be deleted from the selection list.

### <Shop> menu item

If you are using **Nyon**, you have the option of expanding the functionality of your on-board computer with the **<Shop>** menu item in terms of premium functions.

### <Custom riding modes>

With this extension, four different riding modes can be configured. This means that, for each of the four riding modes, the assistance level of the motor support can be set depending on the speed at four points.

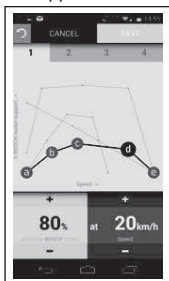

You can configure four different riding modes however you like.

When setting, five definable **checkpoints** or steps are available to you. For the middle three points, you can select any performance assistance required for a certain speed. For the left exterior point, only the performance assistance can be changed (speed is fixed at 0 km/h). For the right right point,

only the maximum speed can be changed (performance assistance is fixed at 0 %). The speed is plotted on the horizontal x-axis and the performance assistance on the vertical y-axis in percent. If you are satisfied with the definition, save the riding mode. The riding mode is then automatically transmitted to Nyon if there is a *Bluetooth*<sup>®</sup> connection.

## Displays and Settings of the Online Portal

**Note:** All interface displays and texts on the following pages correspond to the release status of the software. As the software may be updated over the course of the year, it is possible that the interface displays and/or texts may change.

The following description of the online portal applies to **Kiox** and **Nyon**.

### Online Registration

Internet access is required for online registration.

- Open the **Bosch eBike Connect** online portal at [www.ebike-connect.com](http://www.ebike-connect.com) with your browser.
- Read and accept the General Terms and Conditions and the privacy statement.
- Follow the instructions and complete registration.

Once you have registered, you can log in from this point with your e-mail and password. Alternatively, you can also log in via **Facebook login**. An existing Facebook profile is required for **Facebook login**. The login details from the online portal match the login details of the **Bosch eBike Connect** smart-phone application.



## Online Portal Main Menu

Menu item	Function
<b>&lt;Dashboard&gt;</b>	Your recent activities, statistical data, news and tips are displayed under this menu item.
<b>&lt;Route Planning&gt;</b>	You can plan new routes via this menu item.
<b>&lt;Activities&gt;</b>	The distances you have ridden are displayed under this menu item.
<b>&lt;My eBike&gt;</b>	Via this menu item, you can manage your eBike components and create user-defined views.
<b>&lt;Help&gt;</b>	Under this menu item, you can find FAQs, contact information and further information.
	Under this menu item, you can manage your profile.

### <Route Planning> menu item

The **<Route Planning>** menu item comprises the following submenus:

- **<Build route>**
- **<Explore>**
- **<My Routes>**
- **<Import GPX track>**

#### <Build route>

By specifying the start and end point, you can plan a new route. If required, you can add further intermediate destinations by entering the address.

Addresses or coordinates can be entered in decimal format as start and end points or an intermediate destination. Alternatively, an element can be selected from the list of recent destinations, saved locations or points of interest.

On the map, you can add further intermediate destinations by dragging a point from a route. By right-clicking, you can add a new end point or delete existing points. The start and end point as well as the intermediate points on the map can be moved.

You can choose between three different routes (**<Fast>**, **<Scenic>** and **<MTB>**).

- The **<Fast>** route shows you the fastest connection from your location to your selected destination while avoiding steeper slopes.

- The **<Scenic>** route shows you the most scenic connection from your location to your selected destination and avoids main roads.
- The **<MTB>** route guides you over mostly unpaved trails and offers the best route for a mountain bike (**not** for eBikes up to 45 km/h).

The different **<Fast>**, **<Scenic>** and **<MTB>** routes may be identical on short routes.

The currently selected route is displayed on the map. In addition, the uphill/downhill gradient, distance and estimated trip duration of the selected route are displayed.

When you have built your desired route, save it by pressing **<Save>**.

The saved routes and locations are synchronized with the **eBike Connect** app once they have been saved.

In addition, you can plan the route as a round trip (**<Plan as round trip>**).

If you have an S-Pedelec, the online portal offers you only tracks that are suitable for this eBike type.

If you have connected both a normal Pedelec and an S-Pedelec with the account, you can switch between both eBike types in route planning.

If you are using **Nyon**, the planned route is automatically transmitted to **Nyon** as soon as there is a connection between the app and Nyon.

### **<Explore>**

Under the **<Explore>** menu item, tour suggestions for your surrounding area are offered to you through the "Outdooractive" partner.

You can select one or several tours, which you can save under **<My Routes>**.

### **<My Routes>**

All your saved routes can be accessed and changed here.

A route is automatically synchronized if your on-board computer is connected to the Wi-Fi (only with Nyon) or the eBike Connect smartphone app.

### **<Import GPX track>**

GPX files contain a series of location coordinates (waypoints), the sequence of which describes a route. These GPX files can be used for navigation with the Kiox and Nyon on-board computers. GPX files can be created or edited with the corresponding programs.

Using the **<Import GPX track>** button, you can import GPX files of up to 5 MB to the online portal. The GPX files are saved in the background as soon as the on-board computer is connected to the Internet via a smartphone.

With Nyon, the connection can also be established via Wi-Fi. The on-board computers themselves cannot import GPX files directly via a USB connection.

The routability of GPX tracks depends on the level of detail of the OSM maps. Depending on whether there are streets and paths on which you can ride, the following results are possible.

If you are using **Kiox**:

- GPX track is fully routable.  
Navigation is only possible if the remaining distance is specified. If Kiox is near the starting point, navigation can be started immediately. If Kiox is further away from the starting point, then you must first make your way to the starting point.
- GPX track is not routable.  
The route is statically displayed on Kiox and can be followed by the rider. No distance can be displayed.
- GPX track is partially routable.  
If you are using the modified version, the route will be converted into a fully routable track and saved. If you are keeping the original version, the route will be treated like a non-routable track.

If you are using **Nyon**:

- GPX track is fully routable.  
As usual, navigation including turn-by-turn directions and the specification of the remaining distance and estimated time of arrival is possible. The turn-by-turn directions can be switched off with the top right button. If Nyon is near the starting point, navigation can be started immediately. If Nyon is further away from the starting point, the rider can receive directions to it.
- GPX track is not routable.  
The route is statically displayed on Nyon and can be followed by the rider. No navigational instructions or time calculations can be carried out.
- GPX track is partially routable.  
If you are using the modified version, the route will be converted into a fully routable track and saved. If you are keeping the original version, the route will be treated like a non-routable track.

### <Activities> menu item

You can see here in the overview a summary of all your previously completed activities. Under the **<Activities>** menu item, you can view individual activities in detail.

After synchronization, your journeys are displayed on the map. The synchronization status is displayed on the on-board computer.

When you select a journey, further statistical data is offered to you in addition to the distance and journey duration. The route traveled is displayed on a map. You can illustrate up to two measurands of the journey in a diagram.

If you have used a chest strap, you will also be shown your heart rate.

Incomplete activities will also be displayed after synchronization.

Under **<Options>**, you have the option of exporting the completed activity into various formats or converting the activity into a route.

If you have connected your account to Facebook, you can share the completed activity with your friends on Facebook.

### <My eBike> menu item

Under **<My eBike>**, you can manage your eBike components, and create and adapt custom riding modes (only with Nyon).

### <Help> menu item

Under the **<Help>** menu item, you will find a selection of FAQs, contact information, legal information and information on the system and licenses.

### Profile menu item



You can adapt your profile under **<My profile>**:

- You can change the e-mail address and password, and adjust your fitness data and personal data under **<My profile>**.
- Here you can also select your preferred language for the portal interface.
- You can delete your account on **eBike Connect**.

Under **<Privacy settings>**, you can influence the collection and control of your personal data. The following setting options are available to you:

- **<Geolocation data>**  
Here you can deactivate storage of the location data.
- **<Diagnose and use>**  
Here you can control the use of your user data.

– **<Delete all your eBike activities>**

Here you can delete all eBike activities.

Under **<Connected apps>**, you can connect to the apps of Bosch partners, consequently synchronizing your activities with these apps.

# Maintenance and servicing

## Maintenance and cleaning

Do not clean any of the components with pressurized water.

Keep the screen of your on-board computer clean. Dirt can cause faulty brightness detection.

Clean your on-board computer using a soft cloth dampened only with water. Do not use cleaning products of any kind.

Have your eBike system checked by an expert at least once a year (including mechanical parts, up-to-dateness of system software).

The bike retailer can also schedule the service based on a mileage and/or a time period. In this case, the on-board computer displays a message telling you when the service date is due each time it is switched on.

Please have your eBike serviced and repaired by an authorized bicycle dealer.

► **Only have repairs performed by a certified bicycle dealer.**

## After-sales service and advice on using products

If you have any questions about the eBike system and its components, contact an authorized bicycle dealer.

For contact details of authorized bike dealerships, please visit [www.bosch-ebike.com](http://www.bosch-ebike.com).

## Transport

- ▶ If you transport your eBike attached to the outside of your car, e.g. on a bike rack, remove the on-board computer and the eBike battery to avoid damaging them.

## Battery Recycling Program



The drive unit, on-board computer incl. operating unit, battery, speed sensor, accessories and packaging should be disposed of in an environmentally correct manner.

Do not dispose of eBikes and their components with household waste.



You may recycle your Bosch battery pack by calling 1.800.822.8837.

**Robert Bosch GmbH**

72757 Reutlingen

Germany

**[www.bosch-ebike.com](http://www.bosch-ebike.com)**

**1 270 U20 Ken (2020.09) T / 56**